

Dell PowerEdge C6145
Systems
Hardware Owner's
Manual

Regulatory Model B05S



Notes, Cautions, and Warnings



NOTE: A NOTE indicates important information that helps you make better user of your computer.



CAUTION: A CAUTION indicates potential damage to hardware or loss of data if instructions are not followed.



WARNING: A WARNING indicates a potential for property damage, personal injury, or death.

**Information in this publication is subject to change without notice.
© 2013 Dell Inc. All rights reserved.**

Reproduction of these materials in any manner whatsoever without the written permission of Dell Inc. is strictly forbidden.

Trademarks used in this text: Dell™, the DELL logo, and PowerEdge™ are trademarks of Dell Inc. AMD® is a registered trademark of Advanced Micro Devices, Inc.

Other trademarks and trade names may be used in this publication to refer to either the entities claiming the marks and names or their products. Dell Inc. disclaims any proprietary interest in trademarks and trade names other than its own.

Regulatory Model B05S

May 2013

Rev. A05

Contents

1	About Your System.....	11
	Accessing System Features During Startup	11
	Front-Panel Features and Indicators	12
	Hard-Drive Indicator Patterns	15
	Back-Panel Features and Indicators	17
	NIC Indicator Codes	20
	Power and System Board Indicator Codes	22
	Power Supply Indicator Codes	23
	BMC Heart Beat LED	24
	Post Error Code	25
	Collecting System Event Log (SEL) for Investigation	25
	Post Error Code Event	43
	Other Information You May Need.....	44
	Recovery Mode	45
2	Using the System Setup Program	46
	Start Menu	46
	System Setup Options at Boot	46
	Console Redirection	47
	Main Menu	49
	Main Screen	49
	BIOS Firmware	50
	System Firmware	50

Product Information.....	50
Processor.....	51
System Memory	51
Advanced Menu	52
CPU Configuration	53
Power Management Maximum Performance	56
Power Management OS Control.....	57
Power Management Advanced Platform Management Link	58
Memory Configuration	59
IDE Configuration	60
USB Configuration	64
PCI Configuration	65
Hyper Transport Configuration	69
I/O Virtualization.....	70
Boot Menu	71
Boot Settings Configuration	72
Boot Device Priority.....	74
Hard Disk Drives	75
Removable Drives	76
CD/DVD Drives	77
USB Drives.....	78
Network Drives	79
Security Menu	80
Server Menu.....	82
System Management	84
Remote Access Configuration	85

IPMI Configuration	87
Exit Menu	91
Command Line Interface for Setup Options	92
3 Installing System Components	103
Safety Instructions	103
Recommended Tools	103
Inside the System	104
Hard Drives	105
Removing a Hard-Drive Blank.....	105
Installing a Hard-Drive Blank	106
Removing a Hard-Drive Carrier.....	106
Installing a Hard-Drive Carrier.....	107
Removing a Hard Drive From a Hard-Drive Carrier.....	108
Installing a Hard Drive Into a Hard-Drive Carrier	109
Power Supplies	110
Removing a Power Supply.....	113
Installing a Power Supply	114
System-Board Assembly	115
Removing a System-Board Assembly.....	115
Installing a System-Board Assembly	116
Air Ducts	116
Removing the Air Duct	116
Installing the Air Duct.....	117
Heat Sinks	118
Removing the Heat Sink.....	118

Installing the Heat Sink	119
Processors.....	121
Removing a Processor	122
Installing a Processor	124
Expansion-Card Assembly and Expansion Card	125
Removing the Expansion Card	125
Installing the Expansion Card.....	127
LSI 9260-8i Card	129
Removing the LSI 9260-8i Card.....	129
Installing the LSI 9260-8i Card	132
Cable Routing for LSI 9260-8i Card	133
LSI 9260-8i RAID Battery (Optional).....	135
Removing the LSI 9260-8i RAID Battery	135
Installing the LSI 9260-8i RAID Battery	136
Removing the LSI 9260-8i RAID Battery Carrier.....	137
Installing the LSI 9260-8i RAID Battery Carrier	138
LSI 9265-8i Card	139
Removing the LSI 9265-8i Card.....	139
Installing the LSI 9265-8i Card	142
Cable Routing for LSI 9265-8i Card	143
LSI 9265-8i RAID Battery (Optional).....	145
Removing the LSI 9265-8i RAID Battery Assembly.....	145
Installing the LSI 9265-8i RAID Battery Assembly	146
Removing the LSI 9265-8i RAID Battery	147
Installing the LSI 9265-8i RAID Battery	148
Expansion-Card Connector.....	149

Removing the Expansion-Card Connector.....	149
Installing the Expansion-Card Connector.....	150
Mezzanine Card	151
Removing the SAS Mezzanine Card.....	151
Installing the SAS Mezzanine Card	153
Cable Routing for SAS Mezzanine Card	154
Removing the 10GbE Mezzanine Card	155
Installing the 10GbE Mezzanine Card.....	157
Removing the Mellanox Card	158
Installing the Mellanox Card	160
Mezzanine-Card Bridge Board.....	161
Removing the Mezzanine-Card Bridge Board	161
Installing the Mezzanine-Card Bridge Board.....	162
System Memory	163
Supported DIMM Configuration	163
Removing the Memory Modules.....	166
Installing the Memory Modules	167
System Battery.....	169
Replacing the System Battery.....	169
System Board.....	171
Removing a System Board.....	171
Installing a System Board.....	172
Opening and Closing the System	173
Opening the System.....	174
Closing the System	174
Cooling Fans.....	175

Removing a Cooling Fan.....	175
Installing a Cooling Fan.....	176
Middle Planes.....	177
Removing the Middle Planes.....	177
Installing the Middle Planes.....	182
Backplanes	184
Removing the 3.5" Hard-Drive Backplane.....	184
Installing the 3.5" Hard-Drive Backplane.....	187
Power Distribution Boards	188
Removing a Power Distribution Board.....	188
Installing a Power Distribution Board.....	190
Cable Routing for Power Distribution Board.....	191
Fan Controller Board.....	192
Removing the Fan Controller Board	192
Installing the Fan Controller Board.....	193
Cable Routing for Fan Control Board.....	194
Expander Card (Optional).....	195
Removing the Expander Card.....	195
Installing the Expander Card	199
Front Panels	200
Removing the Front Panel.....	200
Installing the Front Panel.....	203
Sensor Boards	204
Removing the Sensor Board for 3.5" Hard Drive System	204
Installing the Sensor Board for 3.5" Hard Drive System	206
Removing the Sensor Board for 2.5" Hard Drive System	208

	Installing the Sensor Board for 2.5" Hard Drive System	210
4	Troubleshooting Your System	212
	Safety First – For You and Your System	212
	Installation Problems	212
	Troubleshooting System Startup Failure	213
	Troubleshooting External Connections	213
	Troubleshooting the Video Subsystem	213
	Troubleshooting a USB Device	213
	Troubleshooting a Serial I/O Device	214
	Troubleshooting a NIC	215
	Troubleshooting a Wet System	216
	Troubleshooting a Damaged System	217
	Troubleshooting the System Battery	217
	Troubleshooting Power Supplies	218
	Troubleshooting System Cooling Problems	219
	Troubleshooting a Fan	220
	Troubleshooting System Memory	220
	Troubleshooting a Hard Drive	222
	Troubleshooting a Storage Controller	223
	Troubleshooting Expansion Cards	225
	Troubleshooting Processors	226
	IRQ Assignment Conflicts	228
5	Jumpers and Connectors	229
	System Board Connectors	229
	Backplane Connectors	231

3.5" Hard-Drive Backplane With CPLD	231
3.5" Hard-Drive Backplane With Expander.....	232
2.5" Hard-Drive Backplane With Expander.....	233
2.5" Hard-Drive Backplane Expander Card Connectors	234
Middle Plane Connectors	235
Expansion Card Connectors	236
SAS Mezzanine Card Connectors	237
10GbE Mezzanine Card Connectors.....	238
Fan Controller Board Connectors	239
Power Distribution Board Connectors.....	240
Sensor Board Connectors	241
Switch and Jumper Settings	242
System Configuration Switch Settings	242
3.5" Backplane With CPLD Jumper Settings	243
3.5" Backplane With Expander Jumper Settings	244
2.5" Backplane Expander Card Jumper Settings	245
6 Getting Help.....	246
Contacting Dell.....	246
7 Index.....	247

About Your System

Accessing System Features During Startup

The following keystrokes provide access to system features during startup.

Keystroke	Description
<F2>	Enters the System Setup program. See “Start Menu” on page 46.
<F11>	Enters the BIOS Boot Manager. See “System Setup Options at Boot” on page 46.
<F12>	Starts Preboot eXecution Environment (PXE) boot.
<Ctrl><C>	Enters the SAS 2008 Daughter Card Configuration Utility. For more information, see the SAS adapter documentation.
<Ctrl><H>	Enters the LSI 9260 configuration utility. For more information, see the documentation for your SAS RAID card.
<Ctrl><S>	Enters the utility to configure NIC settings for PXE boot. For more information, see the documentation for your integrated NIC.
<Ctrl><HOME>	BIOS recovery during Boot Block.

Front-Panel Features and Indicators

Figure 1-1. Front Panel–3.5" x8 Hard Drives With Two Motherboards

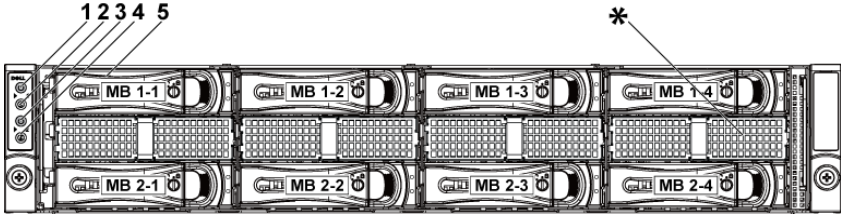

Figure 1-2. Front Panel–3.5" x12 Hard Drives With Two Motherboards

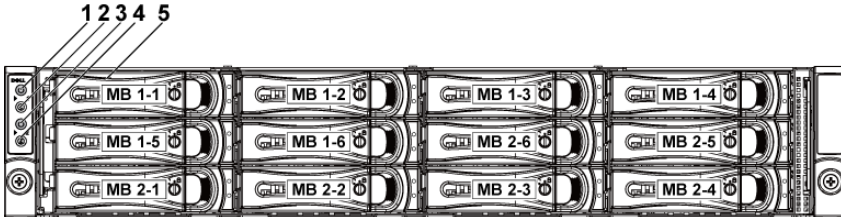

Figure 1-3. Front Panel–3.5" x8 Hard Drives With One Motherboard

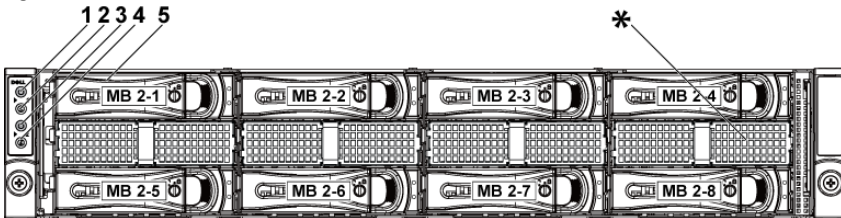

Figure 1-4. Front Panel–3.5" x12 Hard Drives With One Motherboard

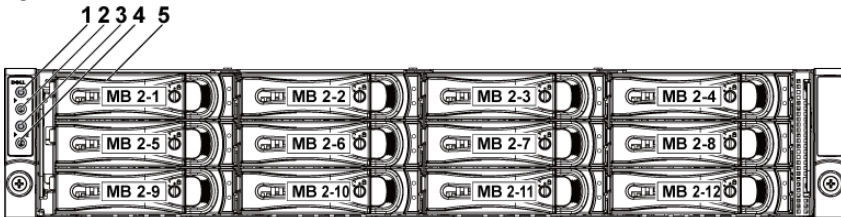

Figure 1-5. Front Panel – 2.5" x18 Hard Drives With Two Motherboards

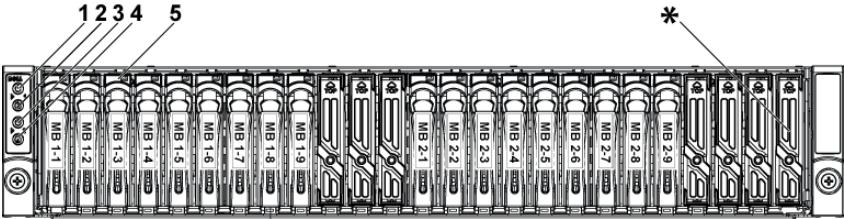

Figure 1-6. Front Panel – 2.5" x24 Hard Drives With Two Motherboards

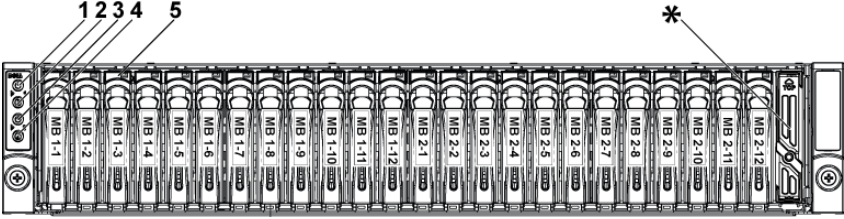
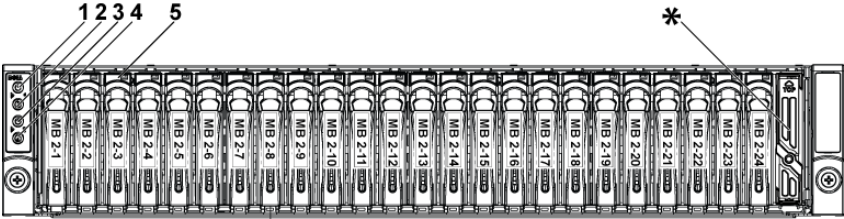



Figure 1-7. Front Panel – 2.5" x24 Hard Drives With One Motherboard



Item	Indicator, Button Or Connector	Icon	Description
1,3	Power-on indicator/ power button (motherboards 1,2)		<p>The power-on indicator lights when the system power is on. The power button controls the DC power supply output to the system.</p> <p>NOTE: When powering on the system, the video monitor can take from several seconds to over 2 minutes to display an image, depending on the amount of memory installed in the system.</p> <p>NOTE: On ACPI-compliant operating systems, turning off the system using the power button causes the system to perform a graceful shutdown before power to the system is turned off.</p> <p>NOTE: To force an ungraceful shutdown, press and hold the power button for 5 seconds.</p>
2,4	System identification indicator/button (motherboards 1,2)		<p>The identification button can be used to locate a particular system and motherboard within a chassis. When the button is pushed, the blue system status indicator on the front blinks until the button is pushed again.</p>
5	Hard Drives		<p>Up to twelve hot-swappable 3.5" hard drives.</p> <p>Up to twenty four hot-swappable 2.5" hard drives.</p>
*	Drive Cover		<p>Different for 2.5" hard drive system and 3.5" hard drive system.</p>

Hard-Drive Indicator Patterns

Figure 1-8. Hard-Drive Indicators

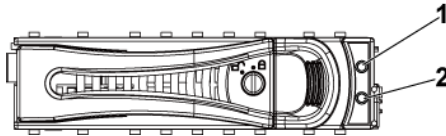

- 1 hard-drive activity indicator (green)
- 2 hard-drive status indicator (green and amber)

Table 1-1. Hard-Drive Status Indicators – For 3.5" Hard-Drive Backplane With CPLD

Hard Drive Type	Function	Activity LED		Status LED	
		Green	Green	Green	Amber
SAS	Slot Empty	Off	Off	Off	Off
	Drive On-line/Access	Blinking when active	On	Off	Off
	Drive Failed	Off/Blinking when active	Off	On 150 ms	Off 150 ms
	Drive Rebuilding	Blinking when active	On 400 ms	Off 100 ms	Off
	Drive Rebuilding Abort	Off/Blinking when active	Off 3000 ms	Off 3000 ms	Off 3000 ms
	Predicted Failure (SMART)	Off/Blinking when active	On 500 ms	Off 500 ms	Off 500 ms
	Drive Identify/Preparing for removal	Blinking when active	On 250 ms	Off 250 ms	Off

Table 1-2. Hard-Drive Status Indicators—For 3.5" Hard-Drive Backplane With Expander

Hard Drive Type	Function	Activity LED	Status LED	
		Green	Green	Amber
SAS	Slot Empty	Off	Off	Off
	Drive On-line/Access	Blinking when active	On	Off
	Drive Failed	Off/ Blinking when active	Off	On 125 ms Off 125 ms
	Drive Rebuilding	Blinking when active	On 400 ms Off 100 ms	Off
	Drive Rebuilding Abort	Off/ Blinking when active	On 3000 ms Off 3000 ms Off 3000 ms Off 3000 ms	Off 3000 ms Off 3000 ms On 3000 ms Off 3000 ms
	Predicted Failure (SMART)	Off/ Blinking when active	On 500 ms Off 500 ms Off 1000 ms	Off 500 ms On 500 ms Off 1000 ms
	Drive Identify/Preparing for removal	Blinking when active	On 250 ms Off 250 ms	Off

Table 1-3. Hard-Drive Status Indicators—For 2.5" Hard-Drive Backplane With Expander

Hard Drive Type	Function	Activity LED	Status LED	
		Green	Green	Amber
SAS	Slot Empty	Off	Off	Off
	Drive On-line/Access	Blinking when active	On	Off
	Drive Failed	Off/ Blinking when active	Off	On 125 ms Off 125 ms
	Drive Rebuilding	Blinking when active	On 400 ms Off 100 ms	Off
	Drive Rebuilding Abort	Off/ Blinking when active	On 3000 ms Off 3000 ms	Off 3000 ms On 3000 ms
	Predicted Failure (SMART)	Off/ Blinking when active	On 500 ms Off 500 ms	Off 500 ms On 500 ms
	Drive Identify/Preparing for removal	Blinking when active	On 250 ms Off 250 ms	Off
			Off 3000 ms	Off 3000 ms
			Off 1000 ms	Off 1000 ms
			Off 1000 ms	Off 1000 ms
			Off 1000 ms	Off 1000 ms
			Off 1000 ms	Off 1000 ms
			Off 1000 ms	Off 1000 ms
			Off 1000 ms	Off 1000 ms

Back-Panel Features and Indicators

Figure 1-9. Back Panel—Two Motherboards

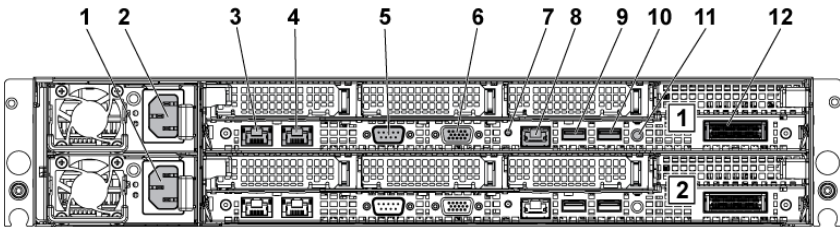
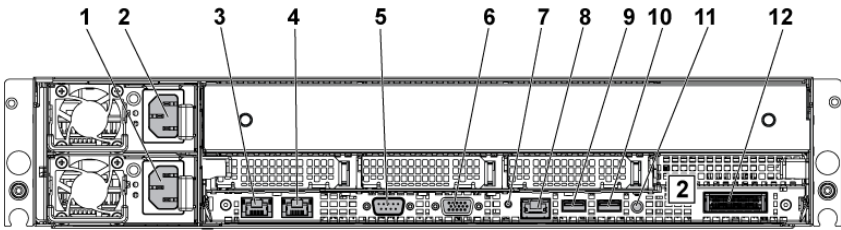











Figure 1-10. Back Panel—One Motherboard



Item	Indicator, Button Or Connector	Icon	Description
1	Power supply 2		1100 W/1400 W
2	Power supply 1		1100 W/1400 W
3	NIC connector 1		Embedded 10/100/1000 NIC connectors.
4	NIC connector 2		Embedded 10/100/1000 NIC connectors.
5	Serial port		Connects a serial device to the system.
6	VGA port		Connects a VGA display to the system.
7	System identification indicator		Both the system management software and the identification buttons located on the front can cause the indicator to flash blue to identify a particular system and system board. Lights amber when the system needs attention due to a problem.
8	BMC management port		Dedicated management port.

Item	Indicator, Button Or Connector	Icon	Description
9	USB port 0		Connects USB devices to the system. The ports are USB 2.0-compliant.
10	USB port 1		Connects USB devices to the system. The ports are USB 2.0-compliant.
11	Power On/Off button		<p data-bbox="620 430 1050 483">The power button controls the DC power supply output to the system.</p> <p data-bbox="620 505 1050 647">NOTE: When powering on the system, the video monitor can take from several seconds to over 2 minutes to display an image, depending on the amount of memory installed in the system.</p> <p data-bbox="620 665 1050 807">NOTE: On ACPI-compliant operating systems, turning off the system using the power button causes the system to perform a graceful shutdown before power to the system is turned off.</p> <p data-bbox="620 825 1050 904">NOTE: To force an ungraceful shutdown, press and hold the power button for five seconds.</p>
12	IPASS connector		Connects to external PCIE devices or a PCIE bus extender port.

NIC Indicator Codes

Figure 1-11. NIC Indicators

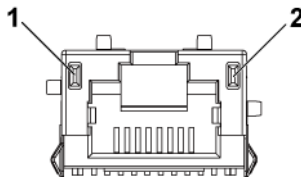

1 speed indicator

2 link/activity indicator

NIC Status Indicator (Speed)	Condition
Solid green	Linking at 100 Mbps speed
Blinking green	Port identification with 10 or 100 Mbps speed
Solid amber	Linking at 1 Gbps speed
Blinking amber	Port identification with 1 Gbps speed
Off	Linking at 10 Mbps speed when the link/activity LED is green; no link when the link/activity LED is off.

NIC Status Indicator (Link/Activity)	Condition
Solid green	LAN linking/No access
Blinking green	LAN accessing
Off	No link

Figure 1-12. NIC Indicators (BMC Management Port)

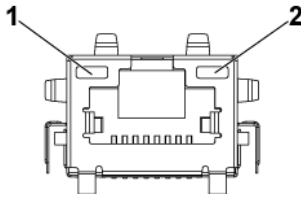

1 speed indicator

2 link/activity indicator

NIC Status Indicator (Speed)	Condition
Green	Linking at 100 Mbps speed
Off	Linking at 10 Mbps speed when the link/activity LED is solid green; no link when the link/activity LED is off
NIC Status Indicator (Link/Activity)	Condition
Green	LAN linking/Accessing
Off	No link

Power and System Board Indicator Codes

The LEDs on the system front panel and back panel display status codes during system startup. For location of the LEDs on the front panel, see Figure 1-1 for 3.5" hard drive and Figure 1-6 for 2.5" hard drive systems. For location of the LEDs on the back panel, see Figure 1-9.

Table 1-4 lists the status associated with the status codes.

Table 1-4. Status Indicator Codes

Component	Indicator		Condition
Power-on indicator	Green	Solid	Power On S0/S1
		Blinking	BMC critical condition event in Power On mode S0/S1
		Off	Power Off mode S4/S5
	Amber	Blinking	BMC Critical condition event in Power On mode S0/S1 BMC Critical condition event in Power Off mode S4/S5
		Off	Power On S0/S1 Power Off S4/S5
System identification indicator	Blue	Solid	IPMI through Chassis Identify Command On or ID Button Press ID On
		Off	IPMI through Chassis Identify Command Off or ID Button Press ID Off

Power Supply Indicator Codes

Figure 1-13. Power Supply Status Indicator

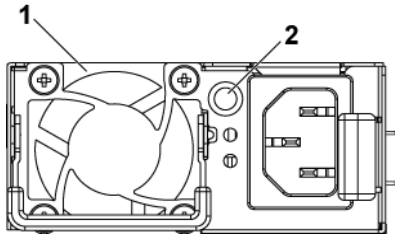

1 power supply

2 AC power LED

AC Power LED	Condition
Solid green	Power supply is on (AC OK/DC OK) or in standby mode (100 VAC-120 VAC for 1023 W, 200 VAC-240 VAC for 1100 W, 200 VAC-240 VAC for 1400 W)
Solid yellow	Power supply is at fault condition (UVP/OVP/OCP/SCP/OTP/Fan Fault)
Off	Power supply is off or AC input voltage is out of normal operating range (100 VAC-120 VAC for 1023 W, 200 VAC-240 VAC for 1100 W, 200 VAC-240 VAC for 1400 W)

BMC Heart Beat LED

The system board provides BMC heart beat LED (CR2) for BMC debugs. The BMC heart beat LED is green. When the system AC power is on, this LED will light. When BMC firmware is ready, the BMC heart beat LED will blink.

Figure 1-14. BMC Heart Beat LED

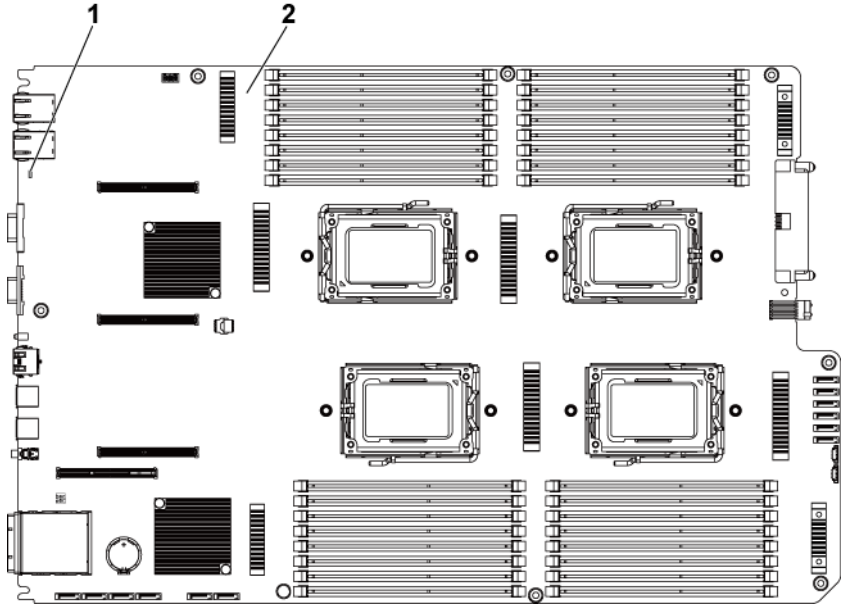

1 BMC heart beat LED

2 system board

Post Error Code

Collecting System Event Log (SEL) for Investigation

Whenever possible, the BIOS will output the current boot progress codes on the video screen. Progress codes are 32-bit quantities plus optional data. The 32-bit numbers include class, subclass, and operation information. The class and subclass fields point to the type of hardware that is being initialized. The operation field represents the specific initialization activity. Based on the data bit availability to display progress codes, a progress code can be customized to fit the data width. The higher the data bit, the higher the granularity of information that can be sent on the progress port. The progress codes may be reported by the system BIOS or option ROMs.

The Response section in the following table is divided into three types:

- 1 **Warning or Not an error** – The message is displayed on the screen. An error record is logged to the SEL. The system will continue booting with a degraded state. The user may want to replace the erroneous unit.
- 2 **Pause** – The message is displayed on the screen, an error is logged to the SEL, and user input is required to continue. The user can take immediate corrective action or choose to continue booting.
- 3 **Halt** – The message is displayed on the screen, an error is logged to the SEL, and the system cannot boot unless the error is resolved. The user needs to replace the faulty part and restart the system.

Error Code	Error Message	Error Cause	Recovery Method
0000h	Timer Error	Timer8254 failed	Board repair
0003h	CMOS Battery Low	CMOS battery low	Change battery
0004h	CMOS Setting Wrong	Diagnostic status byte shown an error	Load CMOS default setting
0005h	CMOS Checksum Bad	CMOS checksum incorrect or BIOS update	Load CMOS default setting
000Bh	CMOS Memory Size Wrong	Base memory size error	Change DIMM or board repair
000Ch	RAM Read/Write Test Failed	No usable system memory	Change DIMM

Error Code	Error Message	Error Cause	Recovery Method
0012h	CMOS Date/Time Not Set	Indicate invalid date/time in CMOS diagnostic status byte	Reset Date/Time
0040h	Refresh Timer Test Failed	Unrecoverable system-board failure	Board repair
0041h	Display Memory Test Failed	Unrecoverable system-board failure	Board repair
0044h	DMA Controller Error	Unrecoverable system-board failure	Board repair
0045h	DMA-1 Error	Unrecoverable system-board failure	Board repair
0046h	DMA-2 Error	Unrecoverable system-board failure	Board repair
0048h	Password Check Failed	Preboot user password violation	Clear password by switch
004Ah	ADM Module Error	Unspecified	Board repair
004Bh	Language Module Error 7	Unspecified	Board repair
005Dh	S.M.A.R.T. Command Failed S.M.A.R.T. Status BAD, Backup and Replace	HDD/ATAPI/IDE device failure	Change HDD
005Eh	Password Check Failed	Other preboot password violation	Clear password by switch
0060h	Primary Master Hard Disk Error	HDD/ATAPI/IDE device failure	Change HDD
0061h	Primary Slave Hard Disk Error	HDD/ATAPI/IDE device failure	Change HDD
0062h	Secondary Master Hard Disk Error	HDD/ATAPI/IDE device failure	Change HDD
0063h	Secondary Slave Hard Disk Error	HDD/ATAPI/IDE device failure	Change HDD
0080h	Primary Master Drive-ATAPI Incompatible	HDD/ATAPI/IDE device failure	Change HDD
0081h	Primary Slave Drive-ATAPI Incompatible	HDD/ATAPI/IDE device failure	Change HDD

Error Code	Error Message	Error Cause	Recovery Method
0082h	Secondary Master Drive-ATAPI Incompatible	HDD/ATAPI/IDE device failure	Change HDD
0083h	Secondary Slave Drive-ATAPI Incompatible	HDD/ATAPI/IDE device failure	Change HDD
0166h	CPU Frequency mismatch!	CPU mix installed is not support	Install same model CPU
0167h	CPUID mismatch!	CPU mix installed is not support	Install same model CPU
0168h	L1 cache size mismatch!	CPU mix installed is not support	Install same model CPU
0169h	L2 cache size mismatch!	CPU mix installed is not support	Install same model CPU
016Ah	CPU Patch level mismatch!	CPU mix installed is not support	Install same model CPU
4168h	DIMM CRC Error or be ignore POST Error	DIMM bad	Change DIMM
4169h	DIMM Chip Select Disable, Test Fail	DIMM bad	Change DIMM
5120h	CMOS cleared by jumper	CMOS clear by jumper	No action
5122h	Password cleared by jumper	Password clear by jumper	No action
8104h	Warning! Port 60h/64h emulation is not supported by this USB Host Controller!!!	Not supported by the HC	Board repair
8105h	Warning! EHCI controller disabled. It requires 64 bit data support in the BIOS.	Check whether this host controller needs 64 bit data structure or not	Board repair
8601h	Error: BMC Not Responding	BMC chip does not find	Board repair
8701h	Insufficient Runtime space for MPS data!! System may operate in PIC or Non-MPS mode.	Failed to copy the MPTable to F000 or E000 shadow RAM	Board repair
8702h	No enough APIC ID in	Check APIC failed	Board repair

Error Code	Error Message	Error Cause	Recovery Method
	range 0-0Fh can be assigned to IO APICs. (Re-assigning CPUs' local APIC ID may solve this issue) MPS Table is not built! System may operate in PIC or Non-MPS mode.		

BMC

Sensor#	Sensor Name	Event	Event Log
Sensor Type: Temperature			
61h	Processor 1 Temp	Upper non-critical event asserted	Processor 1 Temp Temperature Upper Non-Critical - Going High - Asserted
		Upper critical event asserted	Processor 1 Temp Temperature Upper Critical - Going High - Asserted
		Upper non-recoverable event asserted	Processor 1 Temp Temperature Upper Non-Recoverable - Going High - Asserted
		Upper non-critical event deasserted	Processor 1 Temp Temperature Upper Non-Critical - Going High - Deasserted
		Upper critical event deasserted	Processor 1 Temp Temperature Upper Critical - Going High - Deasserted
		Upper non-recoverable event deasserted	Processor 1 Temp Temperature Upper Non-Recoverable - Going High

Sensor#	Sensor Name	Event	Event Log
			- Deasserted
62h	Processor 2 Temp	Upper non-critical event asserted	Processor 2 Temp Temperature Upper Non-Critical - Going High - Asserted
		Upper critical event asserted	Processor 2 Temp Temperature Upper Critical - Going High - Asserted
		Upper non-recoverable event asserted	Processor 2 Temp Temperature Upper Non-Recoverable - Going High - Asserted
		Upper non-critical event deasserted	Processor 2 Temp Temperature Upper Non-Critical - Going High - Deasserted
		Upper critical event deasserted	Processor 2 Temp Temperature Upper Critical - Going High - Deasserted
		Upper non-recoverable event deasserted	Processor 2 Temp Temperature Upper Non-Recoverable - Going High - Deasserted
63h	Processor 3 Temp	Upper non-critical event asserted	Processor 1 Temp Temperature Upper Non-Critical - Going High - Asserted
		Upper critical event asserted	Processor 1 Temp Temperature Upper Critical - Going High - Asserted

Sensor#	Sensor Name	Event	Event Log
		Upper non-recoverable event asserted	Processor 1 Temp Temperature Upper Non-Recoverable - Going High - Asserted
		Upper non-critical event deasserted	Processor 1 Temp Temperature Upper Non-Critical - Going High - Deasserted
		Upper critical event deasserted	Processor 1 Temp Temperature Upper Critical - Going High - Deasserted
		Upper non-recoverable event deasserted	Processor 1 Temp Temperature Upper Non-Recoverable - Going High - Deasserted
		Upper non-critical event asserted	Processor 2 Temp Temperature Upper Non-Critical - Going High - Asserted
		Upper critical event asserted	Processor 2 Temp Temperature Upper Critical - Going High - Asserted
64h	Processor 4 Temp	Upper non-recoverable event asserted	Processor 2 Temp Temperature Upper Non-Recoverable - Going High - Asserted
		Upper non-critical event deasserted	Processor 2 Temp Temperature Upper Non-Critical - Going High - Deasserted
		Upper critical event deasserted	Processor 2 Temp Temperature Upper Critical - Going High - Deasserted

Sensor#	Sensor Name	Event	Event Log
		Upper non-recoverable event deasserted	Processor 2 Temp Temperature Upper Non-Recoverable - Going High - Deasserted
		Upper non-critical event asserted	MLB TEMP 1 Temperature Upper Non-Critical - Going High - Asserted
		Upper critical event asserted	MLB TEMP 1 Temperature Upper Critical - Going High - Asserted
		Upper non-recoverable event asserted	MLB TEMP 1 Temperature Upper Non-Recoverable - Going High - Asserted
21h	MLB TEMP 1	Upper non-critical event deasserted	MLB TEMP 1 Temperature Upper Non-Critical - Going High - Deasserted
		Upper critical event deasserted	MLB TEMP 1 Temperature Upper Critical - Going High - Deasserted
		Upper non-recoverable event deasserted	MLB TEMP 1 Temperature Upper Non-Recoverable - Going High - Deasserted
		Upper non-critical event asserted	MLB TEMP 2 Temperature Upper Non-Critical - Going High - Asserted
22h	MLB TEMP 2	Upper critical event asserted	MLB TEMP 2 Temperature Upper Critical - Going High - Asserted

Sensor#	Sensor Name	Event	Event Log
		Upper non-recoverable event asserted	MLB TEMP 2 Temperature Upper Non-Recoverable - Going High - Asserted
		Upper non-critical event deasserted	MLB TEMP 2 Temperature Upper Non-Critical - Going High - Deasserted
		Upper critical event deasserted	MLB TEMP 2 Temperature Upper Critical - Going High - Deasserted
		Upper non-recoverable event deasserted	MLB TEMP 2 Temperature Upper Non-Recoverable - Going High - Deasserted
		Upper non-critical event asserted	MLB TEMP 3 Temperature Upper Non-Critical - Going High - Asserted
		Upper critical event asserted	MLB TEMP 3 Temperature Upper Critical - Going High - Asserted
23h	MLB TEMP 3	Upper non-recoverable event asserted	MLB TEMP 3 Temperature Upper Non-Recoverable - Going High - Asserted
		Upper non-critical event deasserted	MLB TEMP 3 Temperature Upper Non-Critical - Going High - Deasserted
		Upper critical event deasserted	MLB TEMP 3 Temperature Upper Critical - Going High - Deasserted

Sensor#	Sensor Name	Event	Event Log
		Upper non-recoverable event deasserted	MLB TEMP 3 Temperature Upper Non-Recoverable - Going High - Deasserted
		Upper non-critical event asserted	MLB TEMP 2 Temperature Upper Non-Critical - Going High - Asserted
		Upper critical event asserted	MLB TEMP 2 Temperature Upper Critical - Going High - Asserted
24h	MLB TEMP 4	Upper non-recoverable event asserted	MLB TEMP 2 Temperature Upper Non-Recoverable - Going High - Asserted
		Upper non-critical event deasserted	MLB TEMP 2 Temperature Upper Non-Critical - Going High - Deasserted
		Upper critical event deasserted	MLB TEMP 2 Temperature Upper Critical - Going High - Deasserted
		Upper non-recoverable event deasserted	MLB TEMP 2 Temperature Upper Non-Recoverable - Going High - Deasserted
2Ah	FCB Ambient1	Upper critical event asserted	FCB Ambient1 Temperature Upper Critical - Going High - Asserted
Sensor Type: Voltage			
14h	PS 12V	Lower non-critical event asserted	PS 12V Voltage Lower Non-Critical - Going Low - Asserted

Sensor#	Sensor Name	Event	Event Log
		Lower critical event asserted	PS 12V Voltage Lower Critical - Going Low - Asserted
		Lower non-recoverable event asserted	PS 12V Voltage Lower Non-Recoverable - Going Low - Asserted
		Upper non-critical event asserted	PS 12V Voltage Upper Non-Critical - Going High - Asserted
		Upper critical event asserted	PS 12V Voltage Upper Critical - Going High - Asserted
		Upper non-recoverable event asserted	PS 12V Voltage Upper Non-Recoverable - Going High - Asserted
		Lower non-critical event deasserted	PS 12V Voltage Lower Non-Critical - Going Low - Deasserted
		Lower critical event deasserted	PS 12V Voltage Lower Critical - Going Low - Deasserted
		Lower non-recoverable event deasserted	PS 12V Voltage Lower Non-Recoverable - Going Low - Deasserted
		Upper non-critical event deasserted	PS 12V Voltage Upper Non-Critical - Going High - Deasserted
		Upper critical event deasserted	PS 12V Voltage Upper Critical - Going High - Deasserted
		Upper non-recoverable event deasserted	PS 12V Voltage Upper Non-Recoverable - Going High - Deasserted
15h	PS 5V	Lower non-critical event asserted	PS 5V Voltage Lower Non-Critical - Going Low - Asserted

Sensor#	Sensor Name	Event	Event Log
		Lower critical event asserted	PS 5V Voltage Lower Critical - Going Low - Asserted
		Lower non-recoverable event asserted	PS 5V Voltage Lower Non-Recoverable - Going Low - Asserted
		Upper non-critical event asserted	PS 5V Voltage Upper Non-Critical - Going High - Asserted
		Upper critical event asserted	PS 5V Voltage Upper Critical - Going High - Asserted
		Upper non-recoverable event asserted	PS 5V Voltage Upper Non-Recoverable - Going High - Asserted
		Lower non-critical event deasserted	PS 5V Voltage Lower Non-Critical - Going Low - Deasserted
		Lower critical event deasserted	PS 5V Voltage Lower Critical - Going Low - Deasserted
		Lower non-recoverable event deasserted	PS 5V Voltage Lower Non-Recoverable - Going Low - Deasserted
		Upper non-critical event deasserted	PS 5V Voltage Upper Non-Critical - Going High - Deasserted
		Upper critical event deasserted	PS 5V Voltage Upper Critical - Going High - Deasserted
		Upper non-recoverable event deasserted	PS 5V Voltage Upper Non-Recoverable - Going High - Deasserted
16h	STBY 3.3V	Lower non-critical event asserted	STBY 3.3V Voltage Lower Non-Critical - Going Low - Asserted

Sensor#	Sensor Name	Event	Event Log
		Lower critical event asserted	STBY 3.3V Voltage Lower Critical - Going Low - Asserted
		Lower non-recoverable event asserted	STBY 3.3V Voltage Lower Non-Recoverable - Going Low - Asserted
		Upper non-critical event asserted	STBY 3.3V Voltage Upper Non-Critical - Going High - Asserted
		Upper critical event asserted	STBY 3.3V Voltage Upper Critical - Going High - Asserted
		Upper non-recoverable event asserted	STBY 3.3V Voltage Upper Non-Recoverable - Going High - Asserted
		Lower non-critical event deasserted	STBY 3.3V Voltage Lower Non-Critical - Going Low - Deasserted
		Lower critical event deasserted	STBY 3.3V Voltage Lower Critical - Going Low - Deasserted
		Lower non-recoverable event deasserted	STBY 3.3V Voltage Lower Non-Recoverable - Going Low - Deasserted
		Upper non-critical event deasserted	STBY 3.3V Voltage Upper Non-Critical - Going High - Deasserted
		Upper critical event deasserted	STBY 3.3V Voltage Upper Critical - Going High - Deasserted
		Upper non-recoverable event deasserted	STBY 3.3V Voltage Upper Non-Recoverable - Going High - Deasserted
17h	PS 3.3V	Lower non-critical event asserted	PS 5V Voltage Lower Non-Critical - Going Low - Asserted

Sensor#	Sensor Name	Event	Event Log
		Lower critical event asserted	PS 5V Voltage Lower Critical - Going Low - Asserted
		Lower non-recoverable event asserted	PS 5V Voltage Lower Non-Recoverable - Going Low - Asserted
		Upper non-critical event asserted	PS 5V Voltage Upper Non-Critical - Going High - Asserted
		Upper critical event asserted	PS 5V Voltage Upper Critical - Going High - Asserted
		Upper non-recoverable event asserted	PS 5V Voltage Upper Non-Recoverable - Going High - Asserted
		Lower non-critical event deasserted	PS 5V Voltage Lower Non-Critical - Going Low - Deasserted
		Lower critical event deasserted	PS 5V Voltage Lower Critical - Going Low - Deasserted
		Lower non-recoverable event deasserted	PS 5V Voltage Lower Non-Recoverable - Going Low - Deasserted
		Upper non-critical event deasserted	PS 5V Voltage Upper Non-Critical - Going High - Deasserted
		Upper critical event deasserted	PS 5V Voltage Upper Critical - Going High - Deasserted
		Upper non-recoverable event deasserted	PS 5V Voltage Upper Non-Recoverable - Going High - Deasserted
18h	STBY 1.2V	Lower non-critical event asserted	STBY 3.3V Voltage Lower Non-Critical - Going Low - Asserted

Sensor#	Sensor Name	Event	Event Log
		Lower critical event asserted	STBY 3.3V Voltage Lower Critical - Going Low - Asserted
		Lower non-recoverable event asserted	STBY 3.3V Voltage Lower Non-Recoverable - Going Low - Asserted
		Upper non-critical event asserted	STBY 3.3V Voltage Upper Non-Critical - Going High - Asserted
		Upper critical event asserted	STBY 3.3V Voltage Upper Critical - Going High - Asserted
		Upper non-recoverable event asserted	STBY 3.3V Voltage Upper Non-Recoverable - Going High - Asserted
		Lower non-critical event deasserted	STBY 3.3V Voltage Lower Non-Critical - Going Low - Deasserted
		Lower critical event deasserted	STBY 3.3V Voltage Lower Critical - Going Low - Deasserted
		Lower non-recoverable event deasserted	STBY 3.3V Voltage Lower Non-Recoverable - Going Low - Deasserted
		Upper non-critical event deasserted	STBY 3.3V Voltage Upper Non-Critical - Going High - Deasserted
		Upper critical event deasserted	STBY 3.3V Voltage Upper Critical - Going High - Deasserted
		Upper non-recoverable event deasserted	STBY 3.3V Voltage Upper Non-Recoverable - Going High - Deasserted
19h	PS 1.1V	Lower non-critical event asserted	PS 5V Voltage Lower Non-Critical - Going Low - Asserted

Sensor#	Sensor Name	Event	Event Log
		Lower critical event asserted	PS 5V Voltage Lower Critical - Going Low - Asserted
		Lower non-recoverable event asserted	PS 5V Voltage Lower Non-Recoverable - Going Low - Asserted
		Upper non-critical event asserted	PS 5V Voltage Upper Non-Critical - Going High - Asserted
		Upper critical event asserted	PS 5V Voltage Upper Critical - Going High - Asserted
		Upper non-recoverable event asserted	PS 5V Voltage Upper Non-Recoverable - Going High - Asserted
		Lower non-critical event deasserted	PS 5V Voltage Lower Non-Critical - Going Low - Deasserted
		Lower critical event deasserted	PS 5V Voltage Lower Critical - Going Low - Deasserted
		Lower non-recoverable event deasserted	PS 5V Voltage Lower Non-Recoverable - Going Low - Deasserted
		Upper non-critical event deasserted	PS 5V Voltage Upper Non-Critical - Going High - Deasserted
		Upper critical event deasserted	PS 5V Voltage Upper Critical - Going High - Deasserted
		Upper non-recoverable event deasserted	PS 5V Voltage Upper Non-Recoverable - Going High - Deasserted

Sensor Type: Power Supply

Sensor#	Sensor Name	Event	Event Log
A6h	PSU 1 Present	Presence detected	PSU 1 Present Presence detected - Deasserted
		Configuration Error	PSU 1 Present Configuration Error - Asserted
A7h	PSU 2 Present	Presence detected	PSU 2 Present Presence detected - Deasserted
		Configuration Error	PSU 2 Present Configuration Error - Asserted
Sensor Type: Processor			
41h	CPU1Status	Thermal Trip	CPU1Status Processor Therman Trip - Asserted
42h	CPU2Status	Thermal Trip	CPU2Status Processor Therman Trip - Asserted
43h	CPU3Status	Thermal Trip	CPU3Status Processor Therman Trip - Asserted
44h	CP42Status	Thermal Trip	CPU4Status Processor Therman Trip - Asserted
Sensor Type: Power Unit			
74h	AC Pwr On	AC lost event deasserted	AC Pwr On Power Unit AC Lost - Deasserted
A8h	PSU 1 AC Status	AC lost event asserted	PSU 1 AC Status Power Unit AC Lost - Asserted
A9h	PSU 2 AC Status	AC lost event asserted	PSU 2 AC Status Power Unit AC Lost - Asserted
Sensor Type: System Event			
71h	PEF Action	Alert	PEF Action System Event PEF Action Alert - Asserted
		power off	PEF Action System Event PEF Action power off -

Sensor#	Sensor Name	Event	Event Log
			Asserted
		reset	PEF Action System Event PEF Action reset - Asserted
		power cycle	PEF Action System Event PEF Action power cycle - Asserted
		Diagnostic Interrupt (NMI)	PEF Action System Event PEF Action Diagnostic Interrupt (NMI) - Asserted
Sensor Type: System ACPI Power State			
73h	ACPI Pwr State	Legacy ON state	ACPI Pwr State System ACPI Power State Legacy ON State - Asserted
		Legacy OFF state	ACPI Pwr State System ACPI Power State Legacy OFF State - Asserted
Sensor Type: WatchDog2			
		Timer expired	WatchDog2 Watchdog 2 Timer expired - Asserted
		Hard Reset	WatchDog2 Watchdog 2 Hard Reset - Asserted
72h	WatchDog2	Power Down	WatchDog2 Watchdog 2 Power Down - Asserted
		Power Cycle	WatchDog2 Watchdog 2 Power Cycle - Asserted
		Timer interrupt	WatchDog2 Watchdog 2 Timer interrupt - Asserted
Sensor Type: Event Logging Disable			
40h	SEL Fullness	All Event Logging Disabled	All Event Logging Disabled - Asserted

Sensor#	Sensor Name	Event	Event Log
		SEL Full	SEL Full - Asserted
		SEL Almost Full	SEL Almost Full - Asserted
Sensor Type: Platform Security Violation Attempt			
75h	Security	Out-of-band Access Password Violation	Out-of-band Access Password Violation - Asserted

BIOS

Sensor#	Sensor Name	Event	Event Log (Web UI output)
Sensor Type: System Firmware Progress (formerly POST Error)			
06h	POST Error Code Event	POST Error Code Event	Unknown BIOS POST Progress Error - Asserted
Sensor Type: OEM Reserved			
81h	POST START Event	POST START Event	Unknown OEM RESERVED E/R Type Code : 70h - Asserted
Sensor Type: System Event			
85h	POST OK Event	POST OK Event	Unknown System Event OEM System Boot Event - Asserted
Sensor Type: Memory			
		Correctable ECC/other correctable memory error	Correctable ECC/other correctable memory error - Asserted
60h	Memory	Uncorrectable ECC/other uncorrectable memory error	Uncorrectable ECC/other uncorrectable memory error - Asserted

Sensor#	Sensor Name	Event	Event Log (Web UI output)
		Correctable Memory error logging limit reached	Correctable Memory error logging limit reached - Asserted
		Memory Single/Multi bits Error Event (Single bit) (DIMM Number-CPUx/Chx/DIMx)	Unknown Memory Correctable ECC - Asserted

FCB

Sensor#	Sensor Name	Event	Event Log (Web UI output)
Sensor Type: Fan			
01h	FCB FAN1	Lower critical event asserted	FCB FAN1 Lower Critical - Going Low - Asserted
02h	FCB FAN2	Lower critical event asserted	FCB FAN2 Lower Critical - Going Low - Asserted
03h	FCB FAN3	Lower critical event asserted	FCB FAN3 Lower Critical - Going Low - Asserted
04h	FCB FAN4	Lower critical event asserted	FCB FAN4 Lower Critical - Going Low - Asserted

Post Error Code Event

The BIOS logs the event to the BMC if POST error is detected. Here is an example of event with POST error code 4168h for “Memory Ignore”.

The following table shows the post error code event structure:

Byte	Item	Data
1-2	Record ID	-
3	Record Type	-

Byte	Item	Data
4-7	Timestamp	-
8-9	Generator ID	0x31
10	Event Message Format Version	0x04 (IPMI 2.0)
11	Sensor Type	0x0F (POST Error)
12	Sensor Number	0x06
13	Event Direction/Event Type	0x6F
14	Event Data 1	0xA0
15	Event Data 2	0x68 (Lower 8 bits)
16	Event Data 3	0x41 (Upper 8 bits)

Other Information You May Need



WARNING: See the safety and regulatory information that shipped with your system. Warranty information may be included within this document or as a separate document.

The *Getting Started Guide* provides an overview of rack installation, system features, setting up your system, and technical specifications.



NOTE: Always check for updates on support.dell.com/manuals and read the updates first because they often supersede information in other documents.

Recovery Mode



NOTE: Boot block will be reserved.

A BIOS recovery can be accomplished from one of the following devices: an USB Disk-On-Key or the CD-ROM. The recovery media must include the BIOS image file AMIBOOT.ROM in the root directory.

Two conditions will cause the system to enter the recovery mode:

- Press a hot key <Ctrl><Home>.
- Damage the ROM image, which will cause the system to enter the recovery mode and update the system ROM without the boot block.

The recovery modes are shown as below:

1. Insert or plug-in the recovery media with the AMIBOOT.ROM file.
2. Power on the system, press <Ctrl><Home> and then wait for the recovery process finished.
3. Restart the system and load the BIOS defaulted configurations.

Using the System Setup Program

Start Menu

The system employs the latest AMI CMOS BIOS, which is stored in Flash memory. The Flash memory supports the Plug and Play specification, and contains a System Setup program, the Power On Self Test (POST) routine, and the PCI auto-configuration utility.

This system board supports system BIOS shadowing, enabling the BIOS to execute from 64-bit onboard write-protected DRAM.

This Setup utility should be executed under the following conditions:

- When changing the system configuration, configure for items such as:
 - Hard drives, diskette drives, and peripherals.
 - Password protection from unauthorized use.
 - Power management features.
- When a configuration error is detected by the system and you are prompted to make changes to the Setup utility.
- When redefining the communication ports to prevent any conflicts.
- When changing the password or making other changes to the security setup.



NOTE: Only items in brackets [] can be modified. Items that are not in brackets are display only.

System Setup Options at Boot

<F2>	Initiate Setup during POST
<F9>	Load optimal (for example, CMOS) defaults
<F10>	Save settings and exit in BIOS Setup

Console Redirection

The console redirection allows a remote user to diagnose and fix problems on a server, which has not successfully booted the OS. The centerpiece of the console redirection is the BIOS Console. The BIOS Console is a Flash ROM-resident utility that redirects input and output over a serial or modem connection.

The BIOS supports console redirection to a serial port. If serial port-based headless server support is provided by the system, the system must provide support for redirection of all BIOS-driven console I/O to the serial port. The driver for the serial console must be capable of supporting the functionality documented in the ANSI Terminal Definition.

Please refer to the following steps to set console redirection:

- 1 Enter the BIOS setup menu.
- 2 Select server.
- 3 Select remote access configuration.
- 4 Enable Remote Access.
- 5 Select serial port number:
 - When COM1 is selected:
 - 1) Connect the rs-232 cable between the server and the local computer.
 - 2) The local computer will have the ability to monitor the server screen synchronically through executing the super terminal application.
 - When COM2 is selected (SOL):
 - 1) Check BMC IP from server -> IPMI configuration -> IP Address (current IP address in BMC).
 - a) Make sure BMC NIC under the IPMI configuration. If users select shared NIC, make sure the LAN cable has been plugged in the shared port.
 - ✓ If users have the DHCP server, select BMC IP address source to DHCP.
 - ✓ If users set IP address source to static, enter the BMC themselves in IP address-> IP address.

- b) Make sure BMC NIC under the IPMI configuration. If users select dedicated NIC, make sure the LAN cable has been plugged in the dedicated port.
 - ✓ If users have the DHCP server, select BMC IP address source to DHCP.
 - ✓ If users set IP address source to static, enter the BMC themselves in IP address-> IP address.

Users should take their own risk if they set IP address by themselves. Improper IP setting may cause that they cannot implement communication with BMC over LAN.

- 2) The remote clients should install ipmitool under their operating systems.
- 3) Execute IPMITOOL with BMC IP, username, password and sol parameter like below format:
ipmtool -I <interface> -U <username> -P <password> -H <Host iP> sol activate
- 4) Remote users will have the ability to monitor server screen synchronically through executing the super terminal application.

COM2 is always workable no matter what kind of NIC is selected.

Users only need to make sure BMC current IP exists and IPMI command through LAN is workable, then SOL is workable.

In Figure 1-9, BMC default shared-NIC port is item 3; BMC dedicated port is item 8; and COM1 is item 5.

For detailed configuration of Console Redirection, please refer to “Remote Access Configuration” on page 85.

Main Menu

The main menu displays information about your system boards and BIOS.

Main Screen

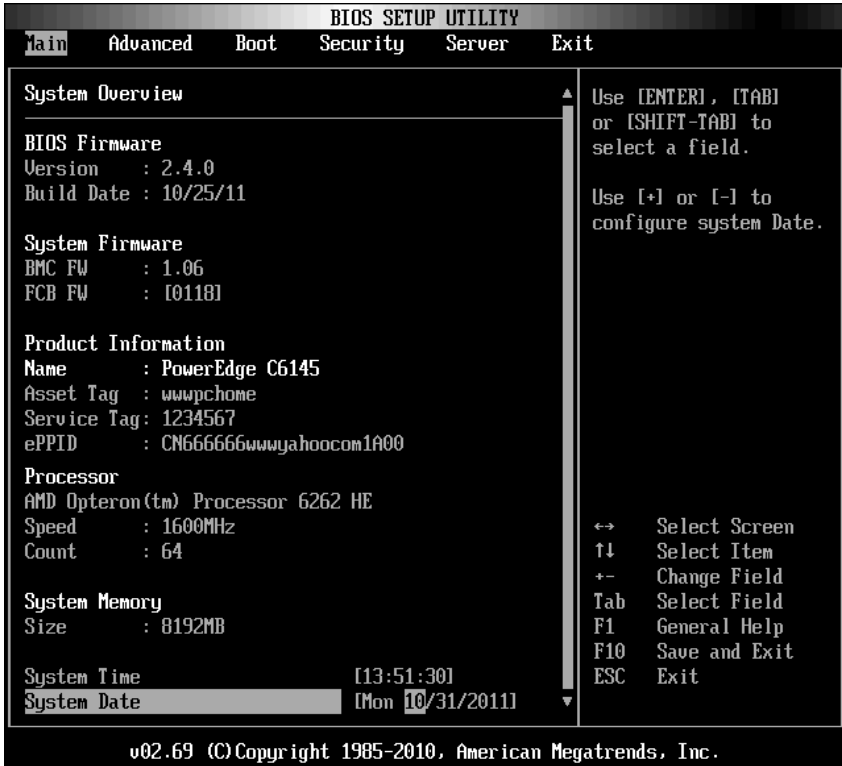



NOTE: The information about BMC/FCB/Asset Tag/Service Tag/ePPID shown in the main menu is different in each server.



NOTE: The options for the System Setup program change based on the system configuration.



NOTE: The System Setup program defaults are listed under their respective options in the following sections, where applicable.

BIOS Firmware

Option	Description
Version	Displays the BIOS version.
Build Date	Displays the BIOS build date.

System Firmware

Option	Description
BMC FW	Displays the system BMC firmware version.
FCB FW	Displays the system FCB firmware version.

Product Information

Option	Description
Name	Displays the name of the product.
AssetTag	Displays the asset tag of the product.
ServiceTag	Displays the service tag of the product.
ePPID	Displays the ePPID of the product.

Processor

Option	Description
Name	Displays the processor name.
Speed	Displays the maximum speed of the processor.
Count	Displays the physical processor count.

System Memory

Option	Description
Size	Displays the total system memory size installed on the system board.
System Date	Displays the current date.
System Time	Displays the current time.

Advanced Menu

This option displays a table of items that defines advanced information about your system.



CAUTION: Making incorrect settings to items on these pages may cause the system to malfunction. Unless you have experience adjusting these items, we recommend that you leave these settings at the default values. If making settings to items on these pages causes your system to malfunction or prevents the system from booting, open BIOS and choose Load Optimal Defaults in the Exit menu to boot up normally.

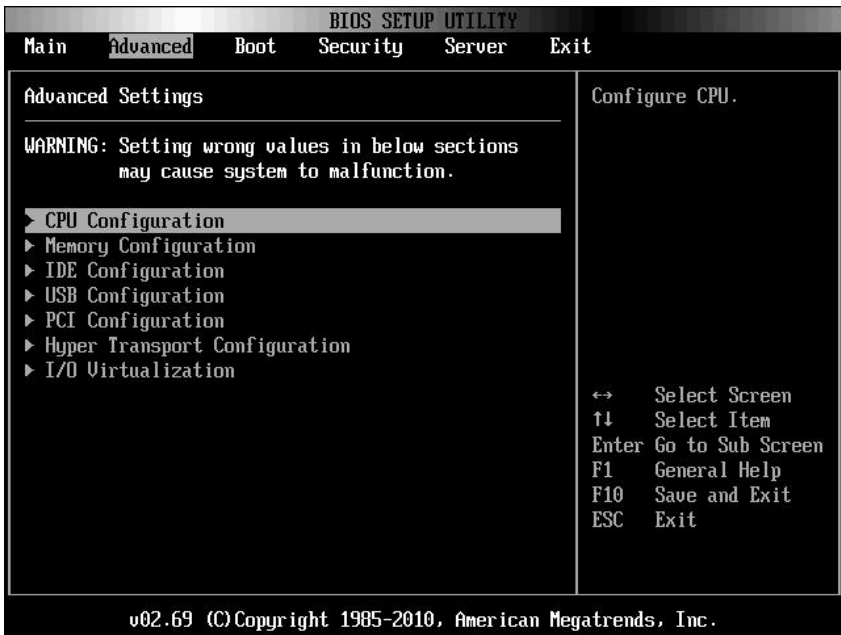

Option	Description
CPU Configuration	Configure CPU.
Memory Configuration	Configure memory.
IDE Configuration	Configure the IDE device(s).

Option	Description
USB Configuration	Configure the USB support.
PCI Configuration	Configure PCI.
Hyper Transport Configuration	Configure Hyper Transport. Power cycle is recommended after change setting.
I/O Virtualization	I/O virtualization.

CPU Configuration

Scroll to this item and press **Enter** to view the following screen:



Option	Description
Module Version	Displays the current processor module version.
Node Count	Displays the node count.
Core Count	Displays the processor core count.
Revision	Displays the processor version.
Cache L1	Displays the size of CPU L1.
Cache L2	Displays the size of CPU L2.
Cache L3	Displays the size of CPU L3.
Speed	Displays the frequency of CPU.
Able to Change Freq.	Displays the capability of frequency change.
uCode Patch Level	Displays the ucode patch level.
Power Management	This field sets the system Power Management to Maximum Performance mode, OS Control mode, or Advanced Platform Management Link mode. When set to APML mode, you can change setting of PSU Power Capping options.
Secure Virtual Machine Mode (Enabled default)	Select this item to enable or disable the function of securing virtual machine mode (SVM).
C1E Support (Enabled default)	Select this item to enable or disable the “Enhanced Halt State”.
CState Mode (C6 default)	Specifies the method of C-State enablement. Only for Family 15h CPU.
CPB Mode (Turbo Mode) (Disabled default)	Specifies the method of core performance boost enablement. Only for Family 15h CPU.
CPU DownCore Mode (All default)	Select this item to cold reset the system after options are changed.
ACPI SRAT Table (Enabled default)	Select this item to enable or disable the building of ACPI SRAT table.

Option	Description
DRAM Prefetcher (Enabled default)	Select this item to enable or disable DRAM Prefetcher.
Hardware Prefetcher (Enabled default)	Select this item to enable or disable the hardware prefetcher. For UP platforms, leave it enabled; For DP/MP servers, it may be used to tune performance to the specific application.
Software Prefetcher (Enabled default)	Select this item to enable or disable the HW Prefetcher Training on Software Prefetch.
IOMMU (Disabled default)	Select this item to enable or disable the IOMMU.
L3 Power Control (Enabled default)	Select this item to enable or disable the L3 Power Control.

Power Management Maximum Performance

Scroll to this item and press **Enter** to view the following screen:

The screenshot shows the BIOS Setup Utility interface. At the top, it says "BIOS SETUP UTILITY" and "Advanced". The main menu is "Power Management Configuration", and the selected item is "Power Management" with the option "[Maximum Performanc]". Below this, it says "Sled Power Capping: Deactivate". On the right side, there is a help text explaining the "POWER mode" and the "Sled Power Capping" feature. At the bottom, there is a legend for navigation keys: ←→ Select Screen, ↑↓ Select Item, +/- Change Option, F1 General Help, F10 Save and Exit, and ESC Exit. The footer of the screen reads "v02.69 (C)Copyright 1985-2010, American Megatrends, Inc."

BIOS SETUP UTILITY	
Advanced	
Power Management Configuration	
Power Management	[Maximum Performanc]
Sled Power Capping: Deactivate	
Set POWER mode. If select Maximum Performance, PowerNow function will be disabled. If select OS control or APML, PowerNow function will be enabled. Sled Power Capping can be activate by DDMI or APML.	
←→	Select Screen
↑↓	Select Item
+ -	Change Option
F1	General Help
F10	Save and Exit
ESC	Exit
v02.69 (C)Copyright 1985-2010, American Megatrends, Inc.	

Option	Description
Power Management (Maximum Performance default)	Set Power mode. If select Maximum Performance PowerNow function will be disabled. If select OS control or APML, PowerNow function will be enabled. Sled Power Capping can be activate by DCMI or APML.

Power Management OS Control

Scroll to this item and press **Enter** to view the following screen:

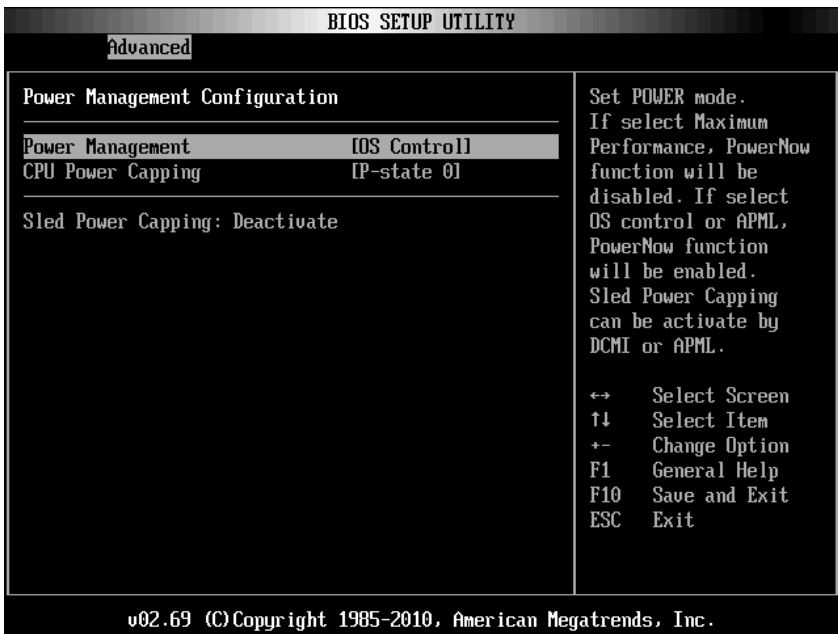

Option	Description
OS Control	Select Power Management to OS control mode.
CPU Power Capping (P-state 0 default)	Sets CPU Power Capping. This option decides the highest performance P-state in OS.

Power Management Advanced Platform Management Link

Scroll to this item and press **Enter** to view the following screen:

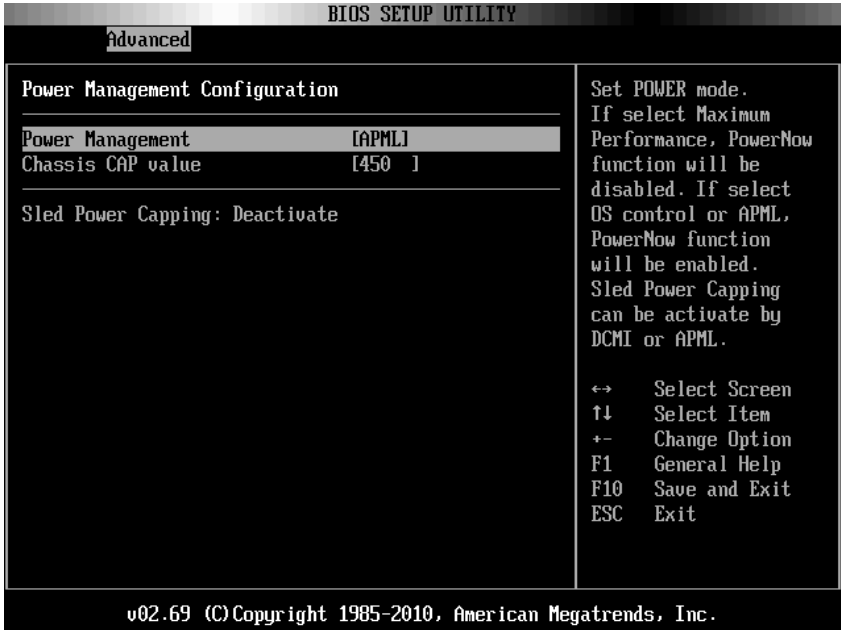

Option	Description
APML	Selects Power Management to AMD Advanced Platform Management Link mode.
Chassis CAP value	The setting controls PSU power with the power wattage limit ranging from 450 to 2800 W. The value is sent to BMC by IPMI command and BMC controls PSU power.

Memory Configuration

Scroll to this item and press **Enter** to view the following screen:

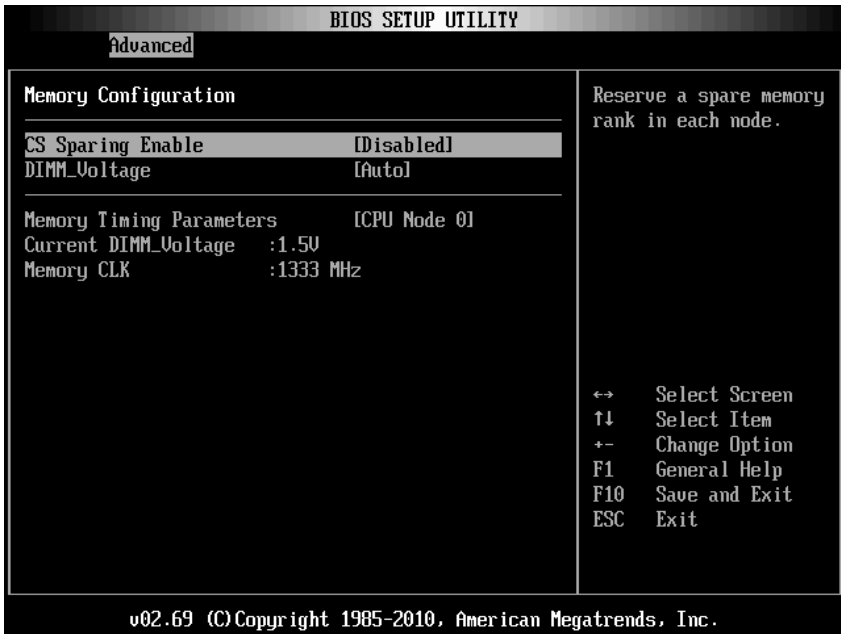

Option	Description
CS Sparing Enable (Disabled default)	Reserves a spare memory rank in each channel. This item will become grey if the memory population cannot support memory sparing.
DIMM Voltage (Auto default)	Controls the DIMM voltage.
Memory Timing Parameter (CPU Node 0 default)	Selects the timing parameters of which node to be displayed.



NOTE: The item will become gray if the Memory population cannot support memory sparing.

IDE Configuration

Scroll to this item and press **Enter** to view the following screen:

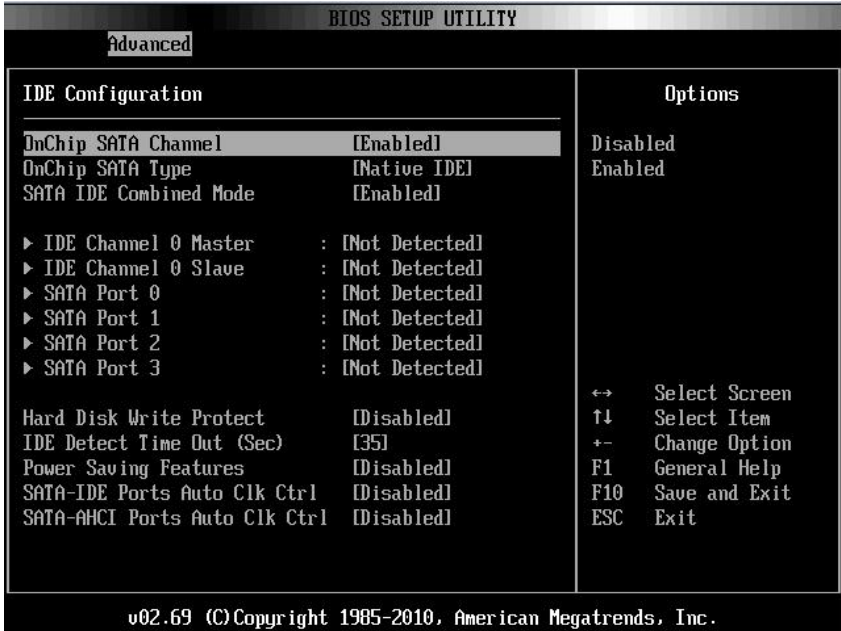

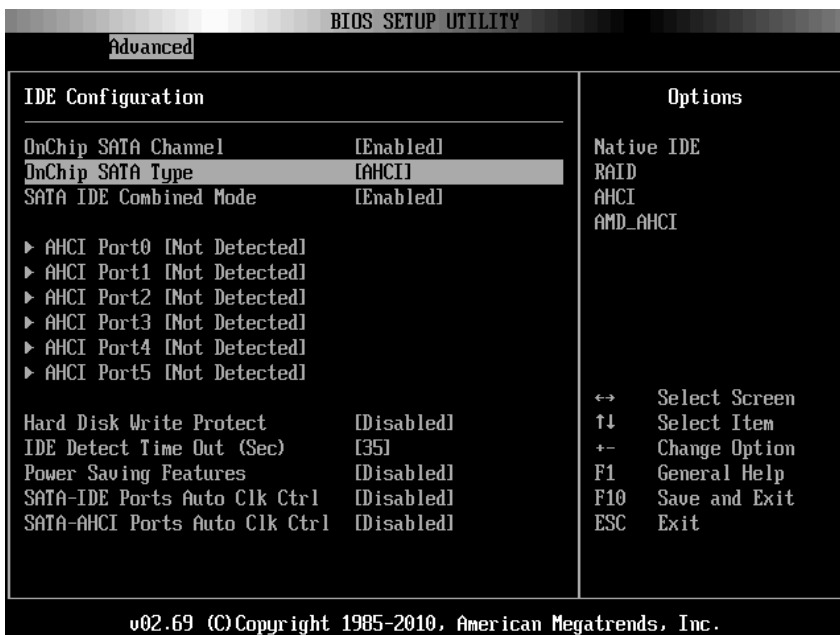

Option	Description
OnChip SATA Channel (Enabled default)	Select this item to enable or disable Onboard SATA controller.
OnChip SATA Type (Native IDE default)	Native IDE: Native mode. AMD_AHCI: Use AMD AHCI option ROM. IDE->AMD_AHCI: No AHCI option ROM, use AMD AHCI driver (need load driver when install OS, windows 2008 R2 had native support.) RAID: Use RAID option ROM.
SATA IDE Combined Mode (Enabled default)	Two SATA (Port 4 and Port 5) share one IDE channel (could be either Primary or Secondary channel) from IDE (PATA) controller.
Hard Disk Write Protect (Disabled default)	Select this item to disable/enable device write protection. This will be effective only if device is accessed through BIOS.

Option	Description
IDE Detect Time Out(Sec) (35 Sec. default)	Select the time out value for detecting ATA/ATAPI device(s).
Power Saving Features (Disabled default)	Disables/Enables power saving features in SB. As general rule, this feature should be disabled for desktop and enabled for mobile.
SATA-IDE Ports Auto Clk Ctrl (Disabled default)	When this option is enabled, the system shuts down the clocks for unused SATA ports in IDE. This enables some power savings. Note: When users shut down the clocks, the hot-plug function for that port will not work.
SATA-AHCI Ports Auto Clk Ctrl (Disabled default)	When this option is enabled, the system shuts down the clocks for unused SATA ports in AHCI modes. This enables some power savings. Note: When users shut down the clocks, the hot-plug function for that port will not work.

AHCI Port0

Scroll to this item and press **Enter** to view the following screen:

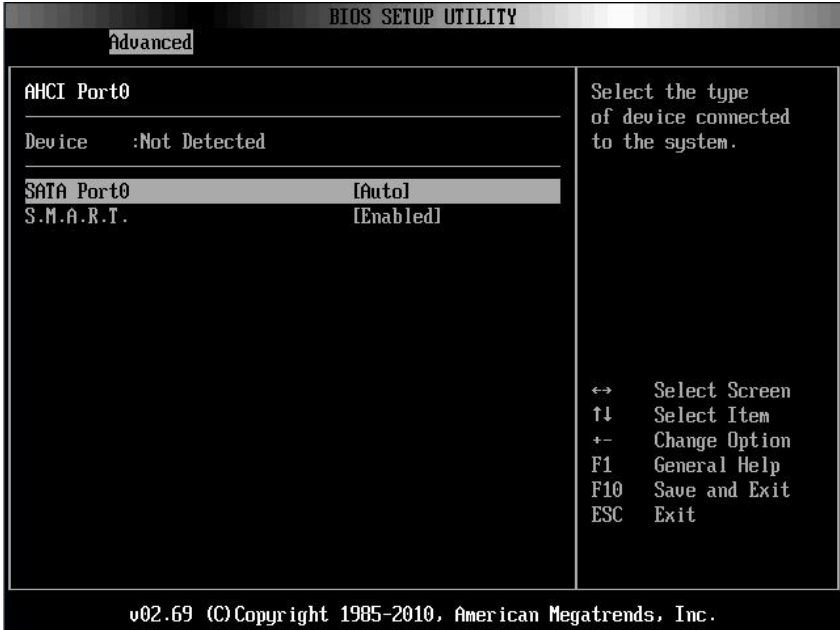

Option	Description
SATA Port0 (Auto default)	Select SATA Port0 to Auto.
S.M.A.R.T	S.M.A.R.T stands for Self-Monitoring Analysis and Reporting Technology.

USB Configuration

Scroll to this item and press **Enter** to view the following screen:

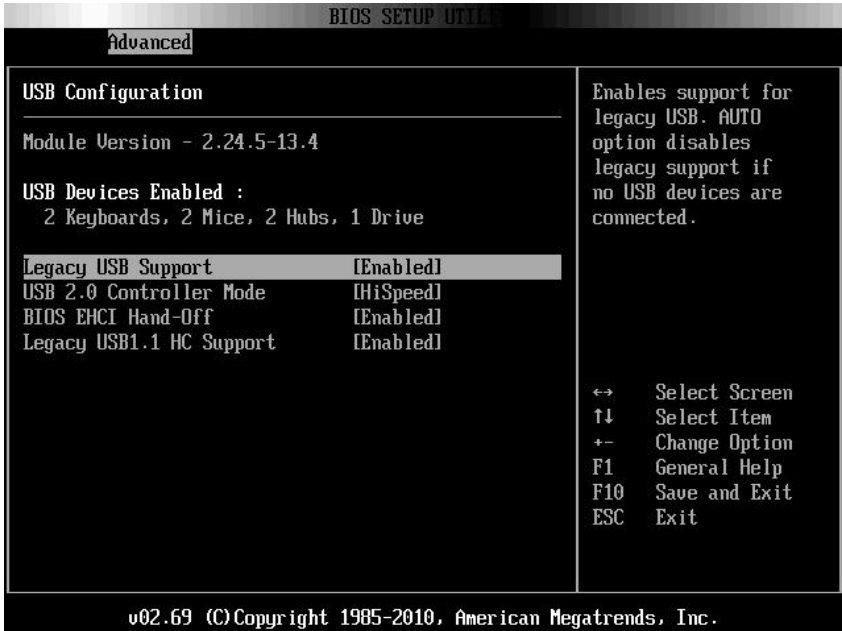

Option	Description
Module Version	Displays the module version.
USB Devices Enabled	Displays USB devices currently detected.
Legacy USB Support (Enabled default)	Select this item to enable or disable legacy USB support.
USB 2.0 Controller Mode (HiSpeed default)	Configure the USB 2.0 controller in HiSpeed (480 Mbps) or FullSpeed (12 Mbps). If user uses USB device (Floppy, CDROM) to install RedHat Linux 9.0, please change USB 2.0 Controller Mode to FullSpeed to workaround it, because RedHat Linux 9.0 is not supported completely for hand-off function.

Option	Description
BIOS EHCI Hand-Off (Enabled default)	This is a workaround for operating systems without EHCI hand-off support. The EHCI ownership change should claim by EHCI driver.
Legacy USB1.1 Support (Enabled default)	Select these items to enable or disable the USB 1.1 HC.

PCI Configuration

Scroll to this item and press **Enter** to view the following screen:

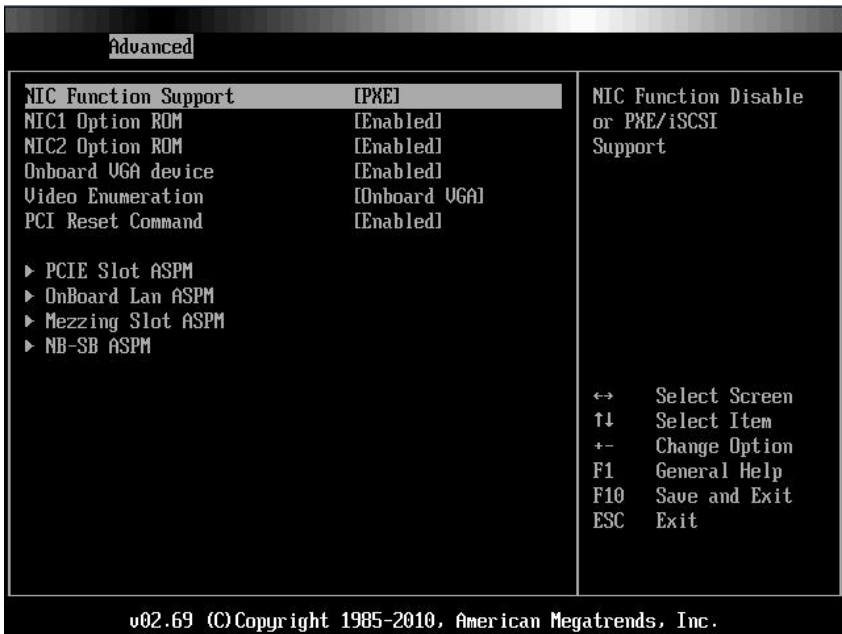

Option	Description
NIC Function Support (PXE default)	NIC for PXE or iSCSI Option ROM support.
NIC1 Option ROM	Disables or enables Option ROM. The “NIC1 Option

Option	Description
(Enabled default)	ROM” is shown in SETUP screen when PXE or iSCSI is set.
NIC2 Option ROM (Enabled default)	Sets OnBoard 82576EB and disables/enables Option ROM. The “NIC2 Option ROM” is shown in SETUP screen when PXE is set.
Onboard VGA device (Enabled default)	Sets onboard VGA chip. The remote KVM function cannot work if this setting is disabled.
Video Enumeration (Onboard VGA default)	Sets Video enumeration.
PCI Reset Command (Enabled default)	Resets the PCI device which behind the HIC card, such as PEC410x GPGPU systems.
PCIE-Slot ASPM	Sets PCIE-Slot ASPM.
Onboard LAN ASPM	Sets Onboard LAN ASPM.
Mezzing Slot ASPM	Sets Mezzing Slot ASPM.
NB-SB ASPM	Sets NB-SB ASPM.

PCI Slot/Onboard LAN/Mezzing Slot ASPM

Scroll to one of these three items and press **Enter** to view the following screen:

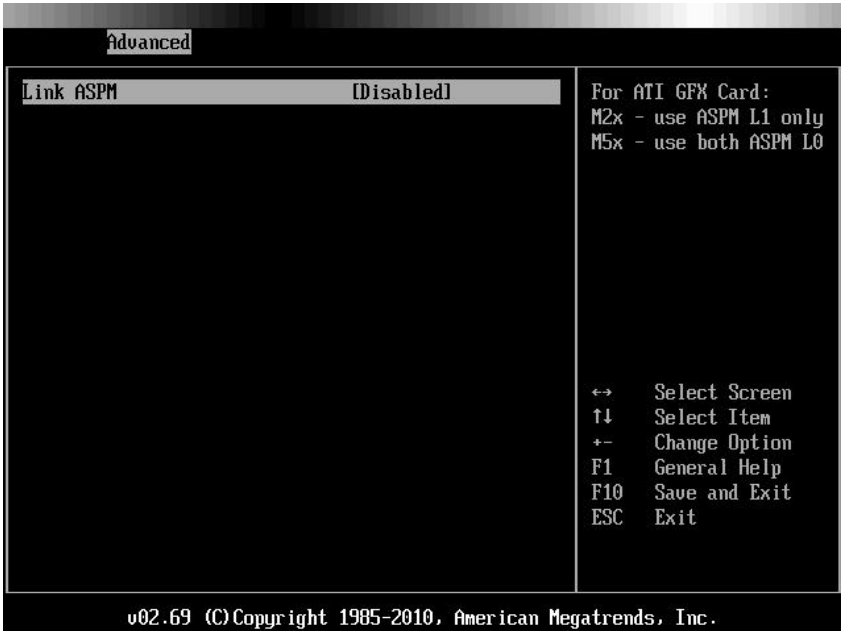

Option	Description
Link ASPM (Disabled default)	For ATI GFX Card: M2x – use ASPM L1 only M5x - use both ASPM L0

NB-SB Port Features

Scroll to this item and press **Enter** to view the following screen:

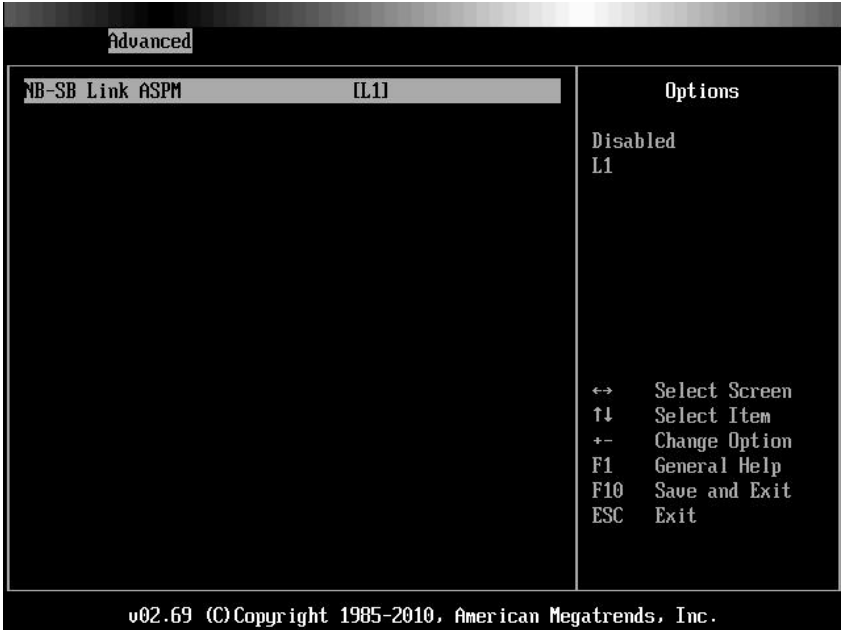

Option	Description
Link ASPM (L1 default)	Sets this item to L1 or to disable.

Hyper Transport Configuration

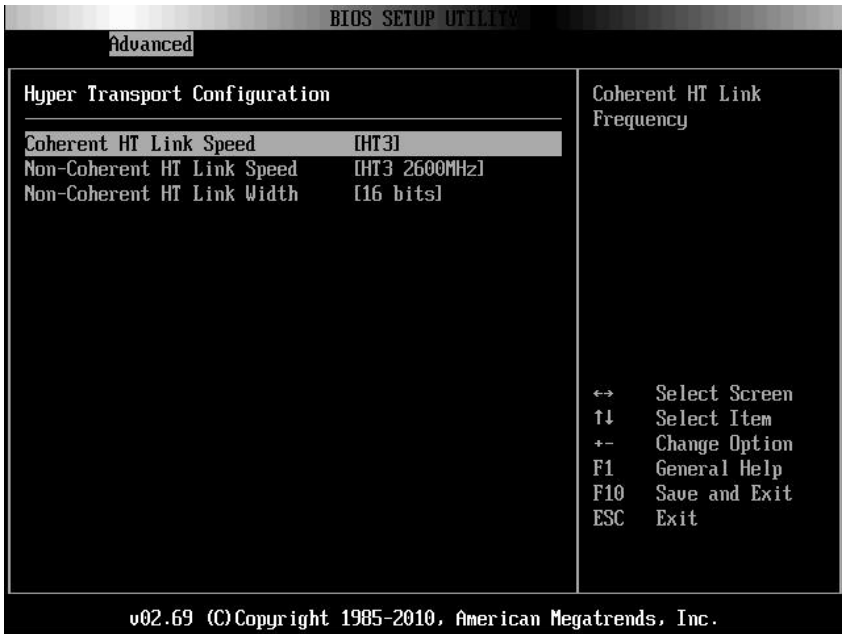

Option	Description
Coherent HT Link Speed (HT3 default)	Coherent HT Link Frequency
Non-Coherent HT Link Speed (HT3 2600MHz default)	Non-Coherent HT Link Frequency
Non-Coherent HT Link Width (16 bits default)	Non-Coherent HT Link Width

I/O Virtualization

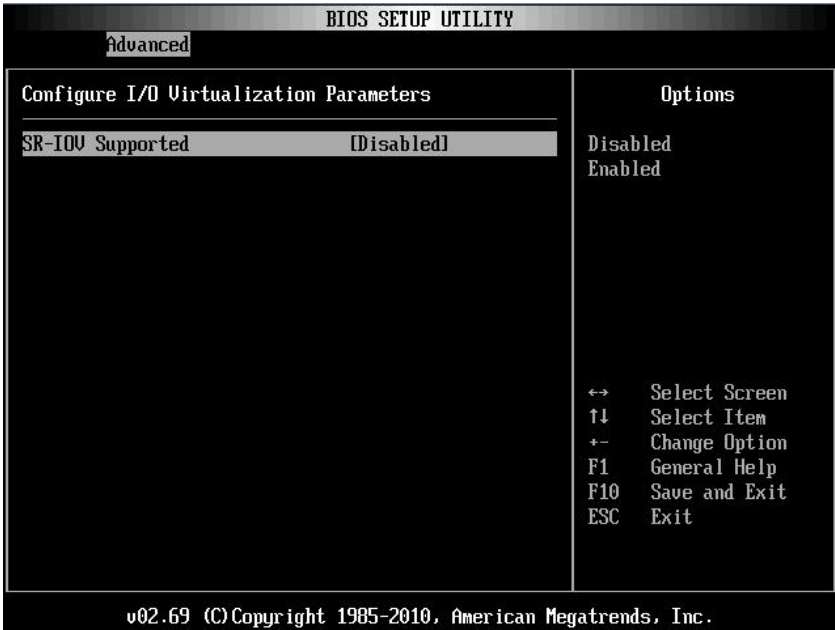

Option	Description
SR-IOV Supported (Disabled default)	Sets this item to enable or to disabe.

Boot Menu

This page enables you to set POST boot parameters. Scroll to this item and press **Enter** to view the following screen:

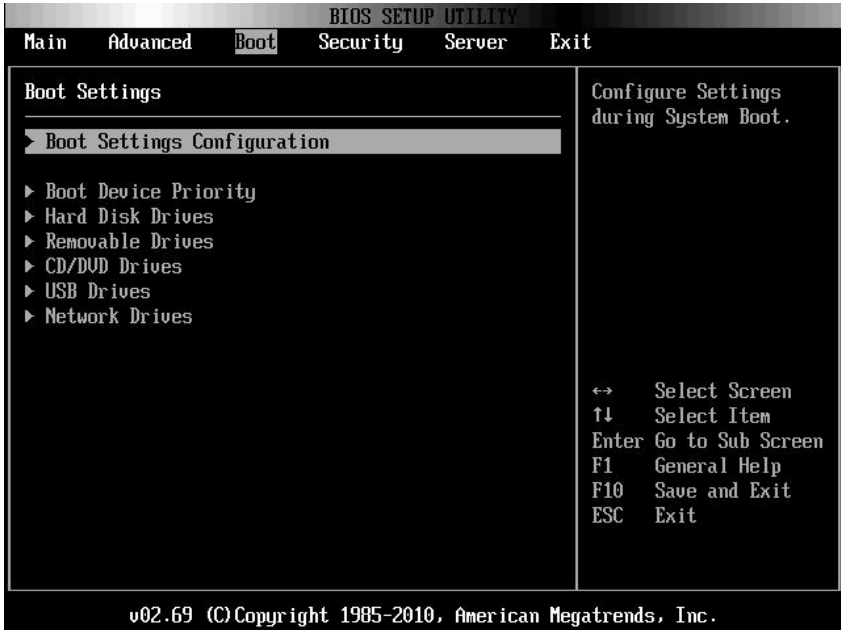

Option	Description
Boot Settings Configuration	Configure Settings during System Boot.
Boot Device Priority	Specifies the Boot Device Priority sequence
Hard Disk Drives	Specifies the Boot Device Priority Sequence from available Hard Drives.
Removable Drives	Specifies the Boot Device Priority sequence from available Removable Drives.
CD/DVD Drives	Specifies the Boot Device Priority sequence from available CD/DVD Drives.

Option	Description
USB Drives	Specifies the Boot Device Priority sequence from available USB Drives.
Network Drives	Specifies the Boot Device Priority sequence from available Network Drives.

Boot Settings Configuration

Select this item and press **Enter** to view the following submenu items:



Option	Description
Quick Boot (Enabled default)	Allow BIOS to skip certain tests while booting, which will decrease the time needed to boot the system.
Quiet Boot (Enabled default)	Disabled: displays normal POST messages. Enabled: displays OEM logo instead of POST

Option	Description
	messages.
Wait For 'F1' if Error (Disabled default)	Wait for F1 key to be pressed if error occurs.
Hit 'F2' Message Display (Enabled default)	Displays "Press F2 to run Setup" in POST.
Force PXE first (Disabled default)	Forces the system to boot by PXE first.
Force PXE Boot only (Disabled default)	Forces the system to boot by PXE only.
Force USB First (Disabled default)	Forces the system to boot from USB first.



NOTE: The following list shows the priority of the boot options (high to low):

- "Force PXE BOOT Only"
- Select boot device by pop menu (press F11 during POST)
- "Force PXE First", press F12 during POST
- "Force USB First"
- boot order in setup menu

Boot Device Priority

Select this item and press **Enter** to view the following submenu items:

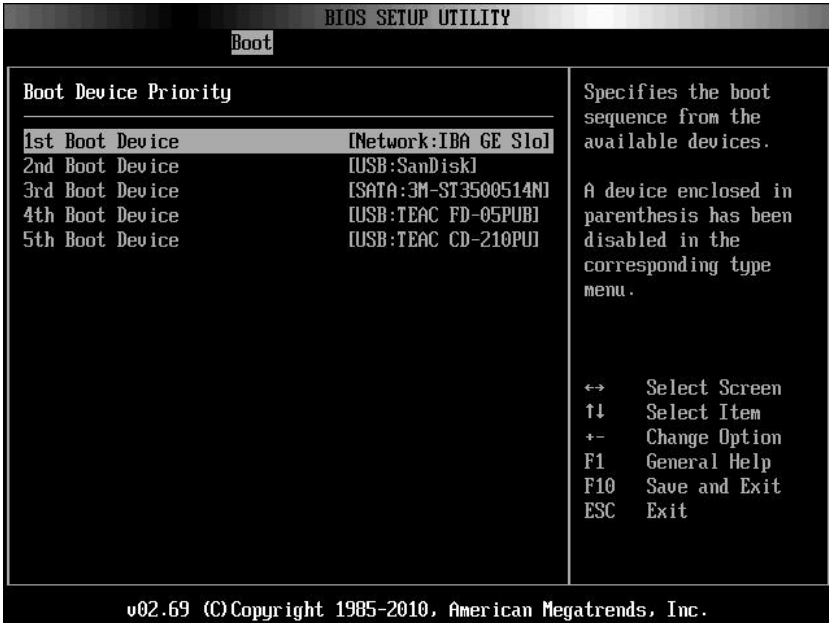

The screenshot shows the BIOS Setup Utility interface. At the top, it says "BIOS SETUP UTILITY" and "Boot". The main area is titled "Boot Device Priority" and contains a list of boot devices. The first device is highlighted: "1st Boot Device [Network:IBA GE Slot]". Other devices include "2nd Boot Device [USB:SanDisk]", "3rd Boot Device [SATA:3M-ST3500514N]", "4th Boot Device [USB:TEAC FD-05PUB]", and "5th Boot Device [USB:TEAC CD-210PU]". To the right of the list, there is explanatory text: "Specifies the boot sequence from the available devices." and "A device enclosed in parenthesis has been disabled in the corresponding type menu." Below this text is a legend for navigation keys: "↔ Select Screen", "↑↓ Select Item", "+- Change Option", "F1 General Help", "F10 Save and Exit", and "ESC Exit". At the bottom of the screen, it says "v02.69 (C) Copyright 1985-2010, American Megatrends, Inc."

Boot Device Priority	
1st Boot Device	[Network:IBA GE Slot]
2nd Boot Device	[USB:SanDisk]
3rd Boot Device	[SATA:3M-ST3500514N]
4th Boot Device	[USB:TEAC FD-05PUB]
5th Boot Device	[USB:TEAC CD-210PU]

Specifies the boot sequence from the available devices.

A device enclosed in parenthesis has been disabled in the corresponding type menu.

↔ Select Screen
↑↓ Select Item
+- Change Option
F1 General Help
F10 Save and Exit
ESC Exit

v02.69 (C) Copyright 1985-2010, American Megatrends, Inc.

Hard Disk Drives

Scroll to this item and press **Enter** to view the following screen:

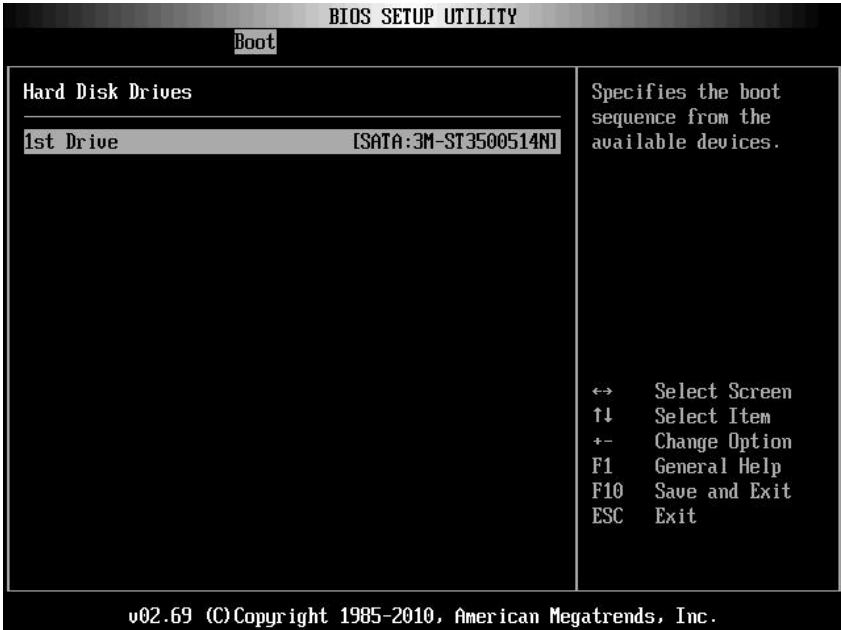

Removable Drives

Scroll to this item and press **Enter** to view the following screen:

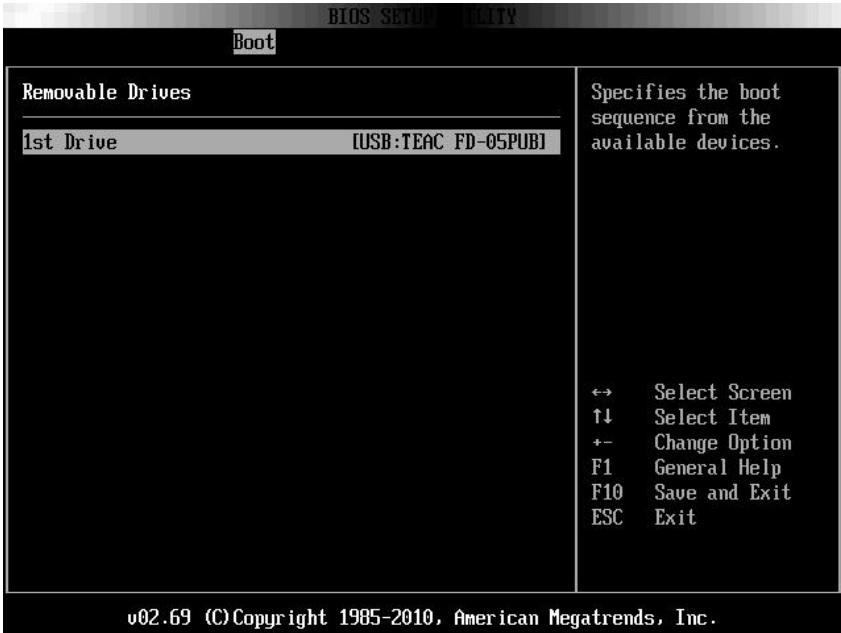

CD/DVD Drives

Scroll to this item and press **Enter** to view the following screen:

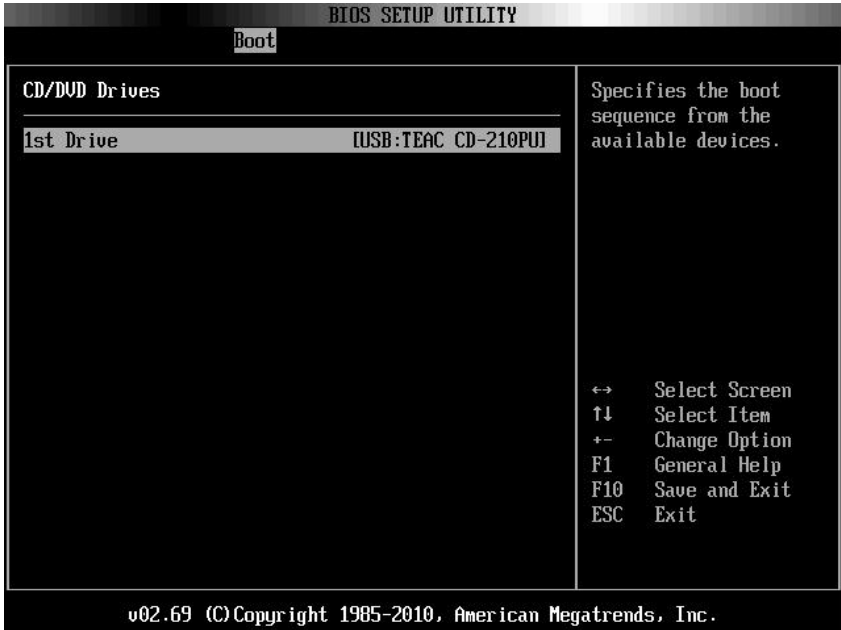

USB Drives

Scroll to this item and press **Enter** to view the following screen:

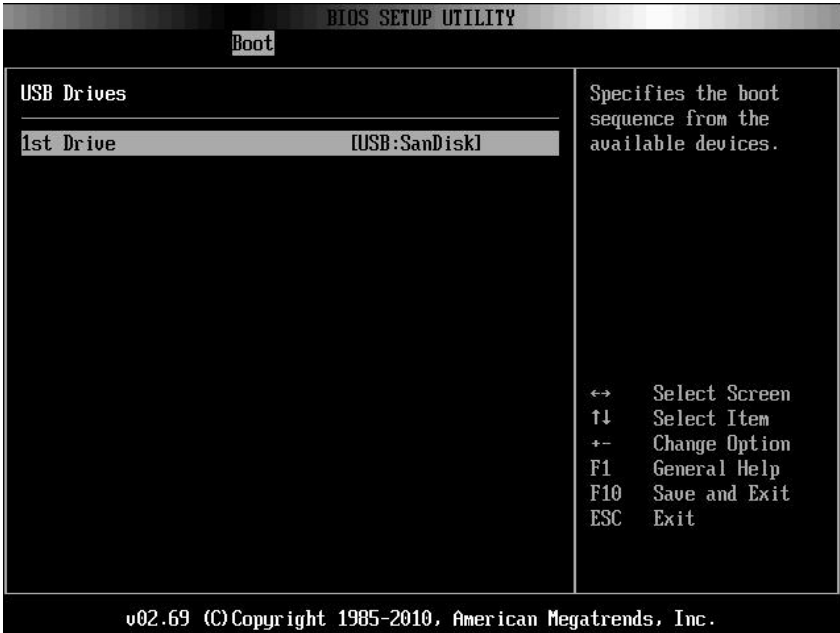

Network Drives

Scroll to this item and press **Enter** to view the following screen:

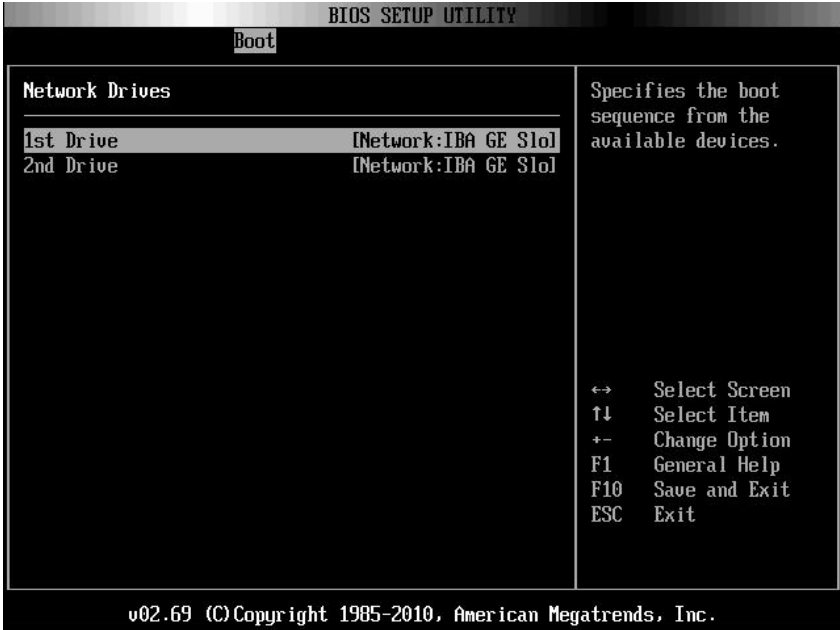

Security Menu

This page enables you to set the security parameters. Scroll to this item and press **Enter** to view the following screen:

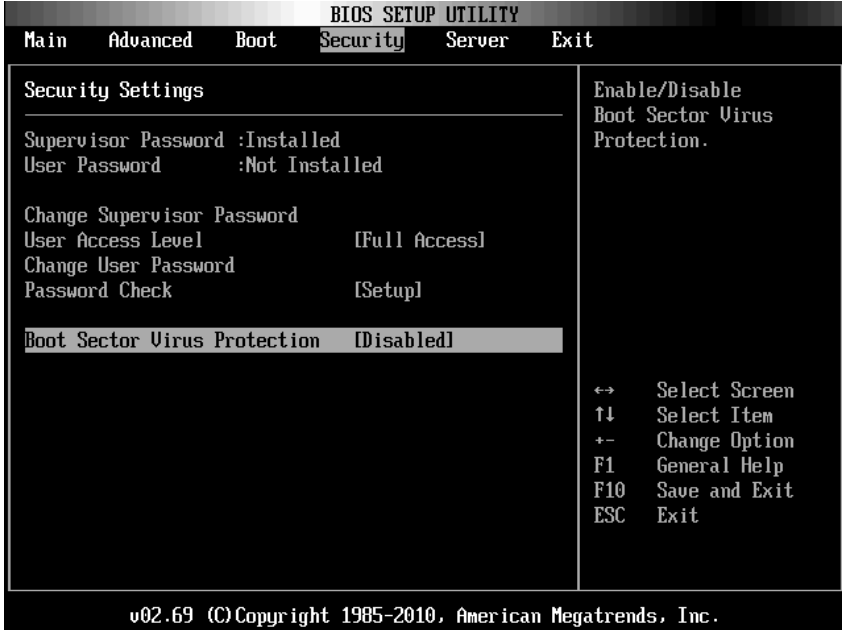

Option	Description
Supervisor Password	Displays whether the supervisor password is installed or not.
User Password	Displays whether the user password is installed or not.
User Access Level (Full Access default)	Sets the access level for users.
Change Supervisor Password	Installs or changes the password.
Change User Password	Installs or changes the password. This item is only shown when the supervisor password is

Option	Description
	set.
Password Check (Setup default)	Setup: Checks password while invoking setup. Always: Checks password while invoking setup as well as on each boot. This item is only shown when the supervisor password is set.
Boot Sector Virus Protection (Disabled default)	Enables or disables Boot Sector Virus Protection.

Server Menu

This page enables you to configure Server parameters. Scroll to this item and press **Enter** to view the following screen:

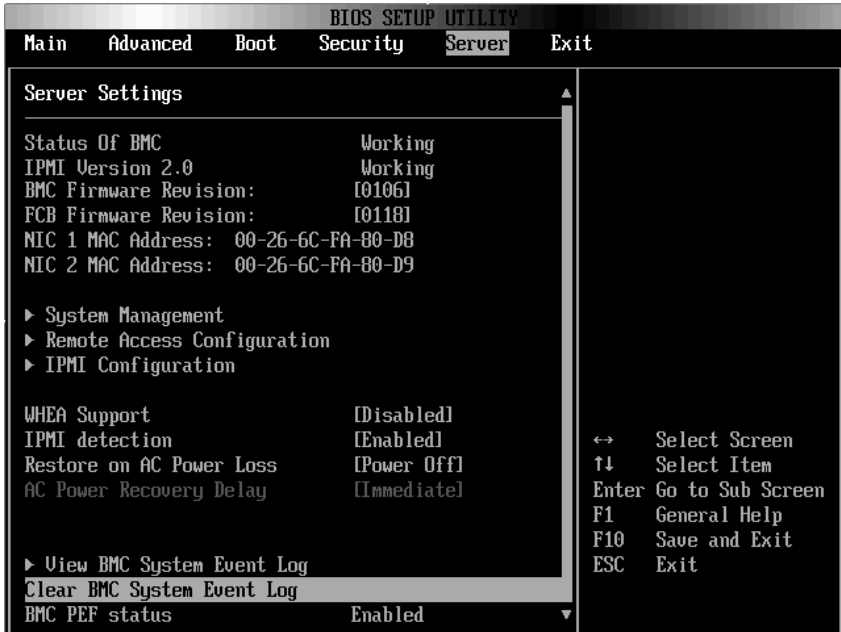

Option	Description
WHEA Support (Disabled default)	Enables or disables Windows Hardware Error Architecture.
IPMI detection	Enables IPMI detection. BMC will be detected by OSs which support plug and play loading of an IPMI driver. Do not enable if your OS does not support this driver.
Restore on AC Power Loss (Power Off default)	System action to take on AC power loss recovery.
AC Power Recovery Delay (Immediate default)	Select the time of system power on after BMC initiate. Immediate: Power on directly after BMC initiate.

Option	Description
	<p>Random: Randomly select time to power on. User define: User selects the time.</p> <p>The “Delay Time” will be shown in the Setup screen when “AC Power Recovery Delay” is set to “User define”. The value of Delay Time will change to 30 after rebooted if it is less than 30. The value of Delay Time will change to 255 after rebooted if it is larger than 255.</p>
View BMC System Event Log	<p>View all events in the BMC Event Log. It will take a maximum of 15 seconds to read all BMC SEL records.</p>
Clear BMC System Event Log	<p>Clears the BMC System Event Log.</p>
BMC PEF Status (Disabled default)	<p>Enables or disables the BMC PEF status.</p>

System Management

Scroll to this item and press **Enter** to view the following screen:

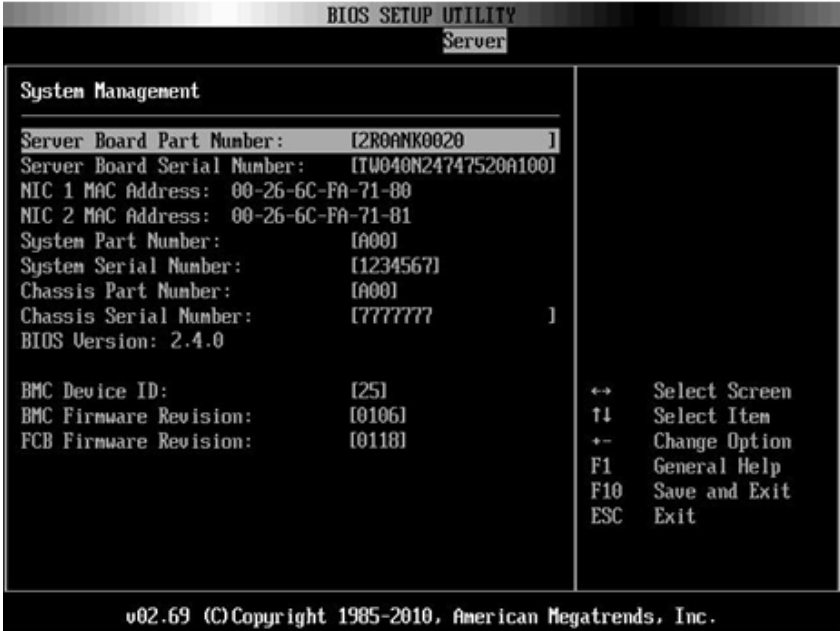

Remote Access Configuration

Scroll to this item and press **Enter** to view the following screen:

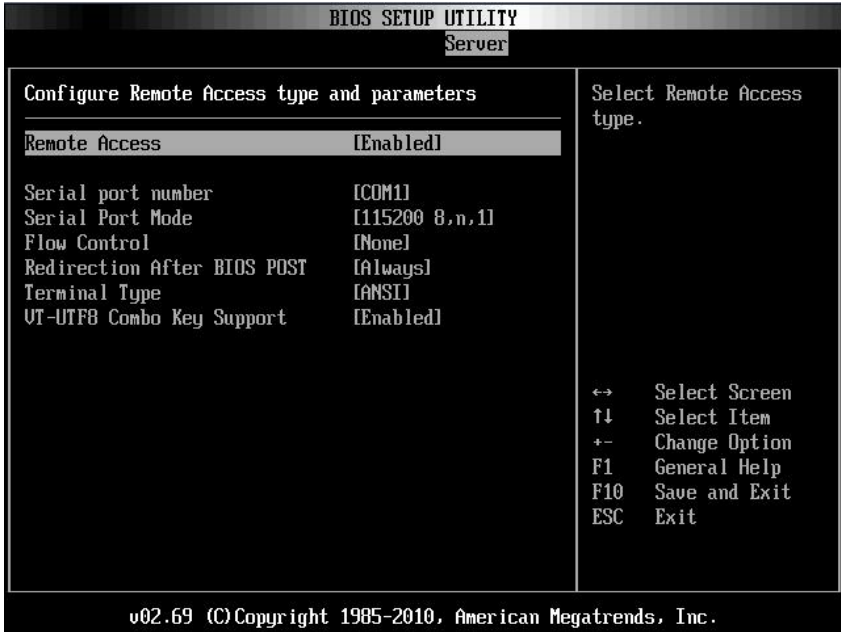

Option	Description
Remote Access (Disabled default)	Select remote access type.
Serial Port Number (COM1 default)	Select serial port for console redirection. Make sure the selected port is enabled. When "Serial Port Number" is set to "COM2", the setting will support SOL.
Serial Port Mode (115200 8,n,1 default)	Select serial port settings.
Flow Control (None default)	Select flow control for console redirection. When setting "Flow Control" to "Software", the

Option	Description
	Hyper Terminal on remote side will be discontinued when <Ctrl> + <S> key is pressed. But onboard NIC PXE Option ROM Configuration is also set when <Ctrl> + <S> key is pressed. Suggest user change the “Setup Key Stroke” to <Ctrl> + in PXE OPRM Configuration. The Hyper Terminal on remote side will be discontinued when <Ctrl> + <S> key is pressed.
Redirection After BIOS POST (Always default)	Disabled: Turns off the redirection after POST. Always: Redirection is always active. (Some operating systems may not work if set to Always.)
Terminal Type (ANSI default)	Select the target terminal type.
VT-UTF8 Combo Key Support (Enabled default)	Enables or disables VT-UTF8 combination key support for ANSI/VT100 terminals.

IPMI Configuration

Scroll to this item and press **Enter** to view the following screen:

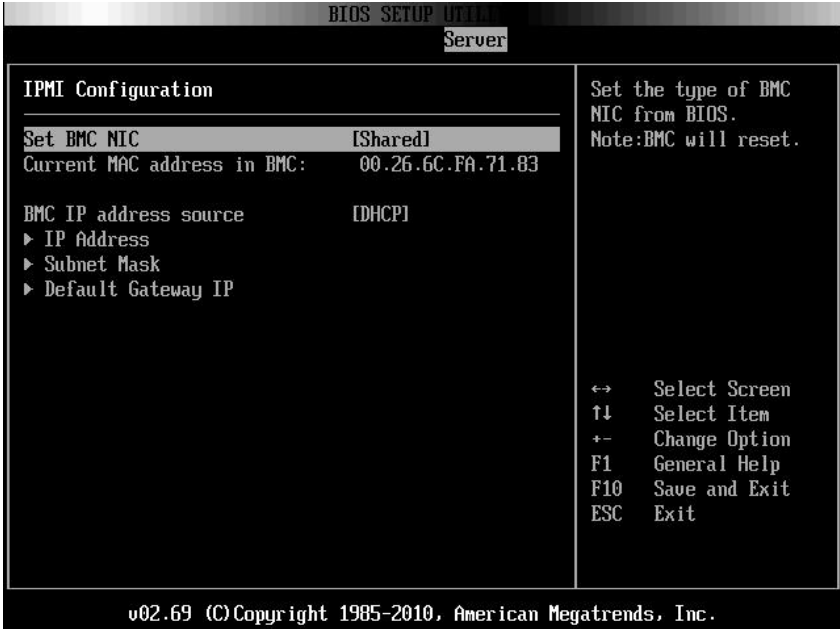

Option	Description
Set BMC NIC (Shared default)	Sets the type of BMC NIC from BIOS. BMC will reset.
BMC IP address source (DHCP default)	Sets BMC IP address source from BIOS.

IP Address Configuration

Select **IP Address** item in the **IPMI Configuration** screen to view the following submenu:

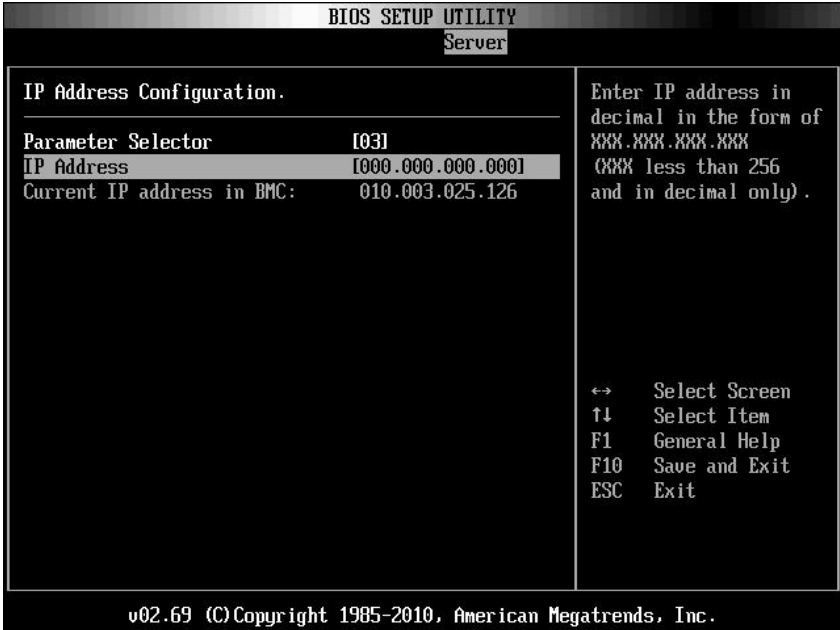

Option	Description
IP Address	Enter IP address in decimal in the form of XXX.XXX.XXX.XXX (XXX less than 256 and in decimal only).



NOTE: When BMC IP status is static, this item is useful.

Subnet Mask Configuration

Select **Subnet Mask** item in the **IPMI Configuration** screen to view the following submenu:

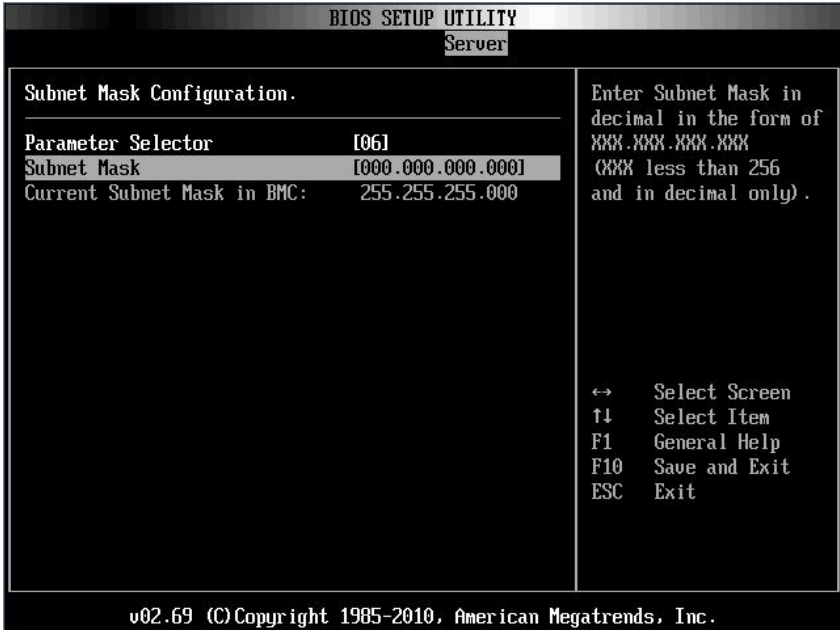

Option	Description
Subnet Mask	Enter Subnet Mask in decimal in the form of XXX.XXX.XXX.XXX (XXX less than 256 and in decimal only).



NOTE: When BMC IP status is static, this item is useful.

Default Gateway IP Configuration:

Select **Default Gateway IP** item in the **IPMI Configuration** screen to view the following submenu:

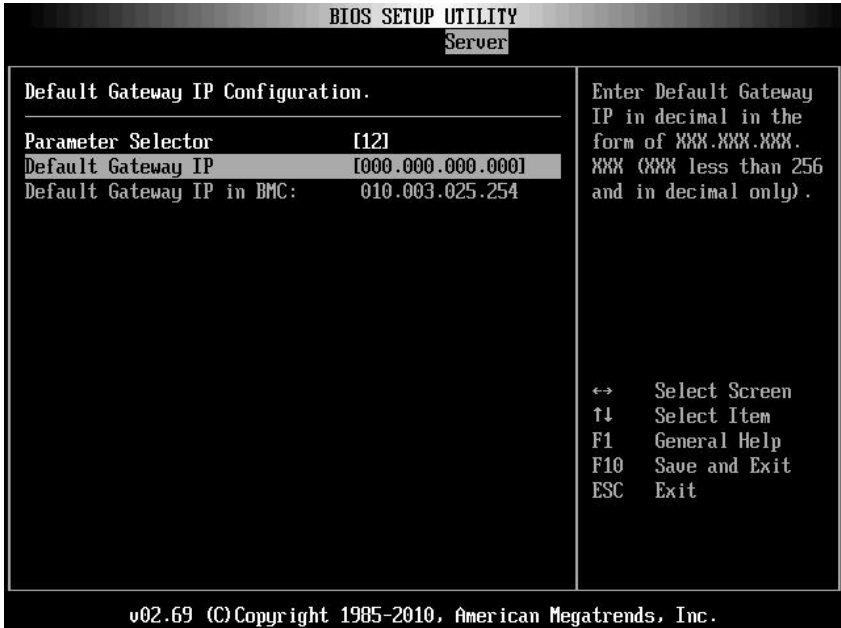

Option	Description
Default Gateway IP	Enter Default Gateway IP in decimal in the form of XXX.XXX.XXX.XXX (XXX less than 256 and in decimal only).

Exit Menu

Scroll to this item and press **Enter** to view the following screen:

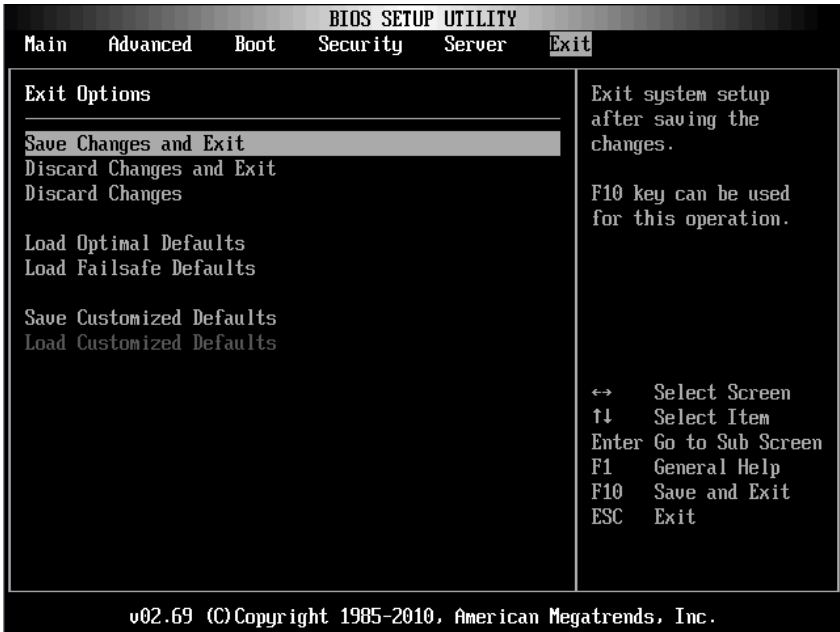

Option	Description
Save Changes and Exit	Exit system setup after saving the changes. F10 key can be used for this operation.
Discard Changes and Exit	Exit system setup without saving any changes. ESC key can be used for this operation.
Discard Changes	Discards changes done so far to any of the setup questions. F7 key can be used for this operation.
Load Optimal Defaults	Loads optimal default values for all the setup questions. F9 key can be used for this operation.
Load Failsafe Defaults	Loads Failsafe Default values for all the setup questions. F8 key can be used for this operation.

Option	Description
Save Customized Defaults	Saves the changes as User Defaults.
Load Customized Defaults	Loads the User Defaults to all the setup options.

Command Line Interface for Setup Options

The options of SETUP menu allow users to control by system configuration utility (syscfg). The utility is included in Dell OpenManage Deployment Toolkit (DTK).

Users can use the utility as following:

- To change the SETUP option by D4 token:
`./syscfg -t=D4_token_id`
(Example: ./syscfg -t=0x002D to enable NIC1 Option ROM)
- To check token activity status:
`./syscfg --istokenactive=D4_token_id`
(Example: ./syscfg --istokenactive=0x002D to check the token activity status of NIC1 Option ROM)
- To change the SETUP option through BMC memory directly:
`./impitool raw <command> <data>`
(Example: ./impitool raw 0xc 1 1 3 10 106 42 120 to set IP address of BMC LAN port as 10.106.42.120)

Table 2-1. The D4 Token Table

Token	Setup Option	Description
002D	NIC1 Option ROM	Enable the system's primary embedded network interface controller (full function), including its PXE boot-ROM.
002E	NIC Function Support	Disable the system's onboard network interface controller.
0051	BOOTSEQ_DSKT	For the next system boot, set the IPL priority to: diskette, hard drive, IDE CD-ROM, option ROMs (if the devices are available)
0052	BOOTSEQ_HDONLY	For the next system boot, set the IPL priority to: hard drive then option

Token	Setup Option	Description
		ROMs (if the devices are available)
0053	BOOTSEQ_DEVLST	For the next system boot, set the IPL priority to: diskette, IDE CD-ROM, hard drive, option ROMs (if the devices are available)
0054	BOOTSEQ_CDROM	For the next system boot, set the IPL priority to: IDE CD-ROM, diskette, hard drive, option ROMs (if the devices are available)
005C	TOKEN_RBU_EN	Enable the system BIOS, on the next reboot, to search for an operating-system-initiated BIOS update image.
005Dh	TOKEN_RBU_DIS	Disable the BIOS update. This value is set by the BIOS on each reboot of the system.
006E	NIC1 Option ROM	Enable the system's primary embedded network interface controller, but does not enable the NIC's associated PXE or RPL boot-ROM.
0087	Onboard VGA	prior Onboard VGA when system power on
0088	Add-in VGA	prior Add-in VGA when system power on
009B	Legacy USB Support	Enable USB emulation
009C	Legacy USB Support	Disable USB emulation
00A1	Restore on AC power Loss	After an AC power loss, when AC power is restored, the system will stay off.
00A2	Restore on AC power Loss	After an AC power loss, when AC power is restored, the system will return to the state was in when power was lost.
00A3	Restore on AC power Loss	After an AC power loss, when AC power is restored, the system will power on.
00BB	NIC2 Option ROM	Enable the system's secondary embedded network interface controller, but does not enable the NIC's associated PXE or RPL boot-ROM.
00BC	NIC2 Option ROM	Enable the system's secondary embedded network interface controller (full-function), including its PXE boot-ROM.
00BF	Remote Access	Serial Console Redirection Off.

Token	Setup Option	Description
00C0	Remote Access	Serial Console Redirection On, output to COM1. See also token D7h.
00CA	CS Sparing Enabled	Disable Redundant memory.
00CB	CS Sparing Enabled	Enable Redundant memory.
00D7	Serial port number	Console redirection to COM2.
00D8	Load Optimal Default	Load Optimal Default.
0135	OnChip SATA Channel	Disable Onboard SATA controller(s).
0137	OnChip SATA type	Onboard SATA controller(s) is set to Native IDE mode.
0138	OnChip SATA type	Onboard SATA controller(s) is set to AHCI mode.
0139	OnChip SATA type	Onboard SATA controller(s) is set to RAID mode
013B	OnChip SATA Channel	Enable Onboard SATA controller(s).
0173	Hardware Prefetcher	Disable CPU HW Prefetcher.
0174	Hardware Prefetcher	Enable CPU HW Prefetcher.
01C4	ACPI SRAT Table	Disable for ACPI SRAT Table.
01C5	ACPI SRAT Table	Enable for ACPI SRAT Table.
021F	Power Management	This will set max. performance.
0221	Power Management	Allow OS to control p-state.
0222	Power Management	Enable APML control.
0224	Onboard VGA device	Enable onboard VGA chip.
0225	Onboard VGA device	Disable onboard VGA chip, the BMC remote KVM function can not work.
0231	CPU DownCore Mode	Enable CPU 4 cores only.
0232	CPU DownCore Mode	Enable CPU 2 cores only.
024D	Wait For 'F1' If Error	Enable the BIOS from prompting for F1/F2 on error. BIOS pauses at F1/F2 prompt.
024E	Wait For 'F1' If Error	Disable the BIOS from prompting for F1/F2 on error. BIOS pauses at F1/F2 prompt.
024F	Quiet Boot	Enable the display of the splash or summary screen, rather than the detail of the POST flow.
0250	Quiet Boot	Disable the display of the splash or

Token	Setup Option	Description
		summary screen. The user is able to see the detail of the POST messages.
026F	CPU DownCore Mode	Enable CPU 6 cores only.
0270	CPU DownCore Mode	Enable CPU 8 core only.
0271	CPU DownCore Mode	Enable CPU 10 cores only.
0272	CPU DownCore Mode	Enable CPU 12 cores only.
0273	CPU DownCore Mode	Enable CPU cores to All.
02A1	C1E Support	Enable CPU C1E support.
02A2	C1E Support	Disable CPU C1E support.
02AD	SR-IOV Supported	Enable SR-IOV Supported
02AE	SR-IOV Supported	Disable SR-IOV Supported
02B6	1.5V DIMM_Voltage	set DIMM voltage to Force 1.5V
02B7	1.35V DIMM_Voltage	set DIMM voltage to Force 1.35V
02B8	Auto DIMM_Voltage	Auto detect DIMM voltage
401A	Terminal Type	The BIOS console redirection, if enabled, operates in VT100 emulation model. See also tokens BFh, C0h, and D7h.
401B	Terminal Type	The BIOS console redirection, if enabled, operates in ANSI emulation model. See also tokens BFh, C0h, and D7h.
401C	Redirection After BIOS POST	The BIOS console redirection, if enabled, continues to operate after the OS boot hand-off.
401D	Redirection After BIOS POST	The BIOS console redirection, if enabled, operates during the BIOS boot only and is disabled prior to OS boot hand-off. See also tokens BFh, C0h, D7h, 401Ah and 401Bh.
4022	Force PXE First	Whenever the system boots from BIOS, the first PXE-capable device is inserted as the first device in the boot sequence. Enabling this feature causes the BIOS operation to occur on the next and all subsequent boots and causes a change in the system's defined boot sequence (unlike tokens 93h and 94h). The BIOS chooses the first PXE-capable

Token	Setup Option	Description
		device as the system's onboard network controller, if present and enabled, or the first bootable network device found in the system's standard PCI search order — whichever comes first.
4023	Force PXE First	Disable the PXE boot override and the system boot sequence is in effect.
4031	Quick Boot	Enabled, skip the system memory tests.
4032	Quick Boot	Disabled, execute the system memory tests.
4033	Serial Port Mode	Console Redirection baud rate will be set to 115,200 bits per second.
4034	Serial Port Mode	Console Redirection baud rate will be set to 57,600 bits per second.
4035	Serial Port Mode	Console Redirection baud rate will be set to 19,200 bits per second.
4036	Serial Port Mode	Console Redirection baud rate will be set to 9,600 bits per second.
4816	Force PXE BOOT Only	Disable Force PXE Boot only.
4817	Force PXE BOOT Only	Enable Force PXE Boot only.
481B	NIC Function Support	Onboard NIC support PXE ROM.
481C	NIC Function Support	Onboard NIC support iSCSI ROM.
481D	Flow Control	Set serial port flow control to none.
481E	Flow Control	Set serial port flow control to hardware.
481F	Flow Control	Set serial port flow control to software.
4820	VT-UTF8 Combo Key Support	Disable VT-UTF8 combo key support.
4821	VT-UTF8 Combo Key Support	Enable VT-UTF8 combo key support.
4822	BMC NIC	Share BMC NIC.
4823	BMC NIC	Dedicate BMC NIC.
4824	BMC IP address source	Set BMC IP address to static.
4825	BMC IP address source	Set BMC IP address to DHCP.
4826	WHEA Support	Disable Windows 2008 R2 WHEA support.
4827	WHEA Support	Enable Windows 2008 R2 WHEA support.

Token	Setup Option	Description
482A	Serial port number	Console redirection to COM1.
482B	Terminal Type	The BIOS console redirection, if enabled, operates in VT-UTF8 emulation model. See also tokens BFh, C0h, and D7h.
4832	OnChip SATA type	Onboard SATA controller(s) is set to AMD_AHCI mode
4840	Force USB First	Disable USB drivers as first boot device.
4841	Force USB First	Enable USB to be the first boot device, the priority is higher than PXE. It will take effect on next boot.
4842	Redirection After BIOS POST	The BIOS console redirection, if enabled, continues to operate until boot loader.
4843	IPMI Detection	Disable for BMC DUP execute.
4844	IPMI Detection	Normally, enable IPMI detection.
4856	IOMMU	Disable IOMMU device.
4857	IOMMU	Enable IOMMU device.
4858	Secure Virtual Machine Mode	Enable Secure Virtual Machine Mode.
4859	Secure Virtual Machine Mode	Disable Secure Virtual Machine Mode.
485E	USB 2.0 Controller Mode	Set USB controller mode to Full speed.
485F	USB 2.0 Controller Mode	Set USB controller mode to High speed.
4860	BIOS EHCI Hand-Off	Enable USB EHCI Hand-Off.
4861	BIOS EHCI Hand-Off	Disable USB EHCI Hand-Off.
4866	CPU Power Capping	Set CPU power state limit to P0.
4867	CPU Power Capping	Set CPU power state limit to P1.
4868	CPU Power Capping	Set CPU power state limit to P2.
4869	CPU Power Capping	Set CPU power state limit to P3.
486A	CPU Power Capping	Set CPU power state limit to P4.
486E	PSU Power Capping	Disable BMC power support throttle control.
486F	PSU Power Capping	Enable BMC power support throttle control.
4871	SATA-AHCI Ports Auto Clk Ctrl	Disable SATA-AHCI port clock control.
4872	SATA-AHCI Ports Auto Clk	Enable SATA-AHCI port clock control.

Token	Setup Option	Description
	Ctrl	
4873	SATA-IDE Ports Auto Clk Ctrl	Disable SATA-IDE port clock control.
4874	SATA-IDE Ports Auto Clk Ctrl	Enable SATA-IDE port clock control.
4877	L3 Power Control	Disable the clock stop for an idle subcache.
4878	L3 Power Control	Enable the clock stop for an idle subcache.
4883	NB-SB Link ASPM	Disable NB-SB link ASPM.
4884	NB-SB Link ASPM	Set NB-SB link ASPM to L1.
4887	Coherent HT Link Speed	Set Coherent HT link to HT1.
4888	Coherent HT Link Speed	Set Coherent HT link to HT3.
4891	Power Saving Features	Disable dynamic power saving function for SATA core clock.
4892	Power Saving Features	Enable dynamic power saving function for SATA core clock.
48A2	Non-Coherent HT Link Speed	Set Non-Coherent HT Link Speed to HT1 1200Mhz.
48A4	Non-Coherent HT Link Speed	Set Non-Coherent HT Link Speed to HT3 2000Mhz.
48A5	Non-Coherent HT Link Speed	Set Non-Coherent HT Link Speed to HT3 2600Mhz.
48A6	Non-Coherent HT Link Width	Set Non-Coherent HT Link Width 8 bits.
48A7	Non-Coherent HT Link Width	Set Non-Coherent HT Link Width 16 bits.
48B9	DRAM Prefetcher	Disable DRAM prefetcher.
48BA	DRAM Prefetcher	Enable DRAM prefetcher.
48BD	Software Prefetcher	Disable HW Prefetcher Training on SW.
48BE	Software Prefetcher	Enable HW Prefetcher Training on SW.
5001	PCIE-Slot ASPM	Disable PCIE-Slot ASPM.
5002	PCIE-Slot ASPM	Set PCIE-Slot ASPM to L0.
5003	PCIE-Slot ASPM	Set PCIE-Slot ASPM to L1.
5004	PCIE-Slot ASPM	Set PCIE-Slot ASPM to L0 & L1.
5021	Onboard Lan ASPM	Disable Onboard NIC ASPM.

Token	Setup Option	Description
5022	Onboard Lan ASPM	Set Onboard NIC ASPM to L0.
5023	Onboard Lan ASPM	Set Onboard NIC ASPM to L1.
5024	Onboard Lan ASPM	Set Onboard NIC ASPM to L0 & L1.
5091	Mezzing Slot ASPM	Disable Mezzing Slot ASPM.
5092	Mezzing Slot ASPM	Set Mezzing Slot ASPM to L0.
5093	Mezzing Slot ASPM	Set Mezzing Slot ASPM to L1.
5094	Mezzing Slot ASPM	Set Mezzing Slot ASPM to L0 & L1.
5097	SATA IDE Combined Mode	Disable SATA IDE combined mode, if only AHCI mode is used, the item needs to be set disabled for port4 & port5.
5098	SATA IDE Combined Mode	Enabled, two SATA ports (port 4 & port 5) share one IDE channel.
5103	PCI Reset	Enabled PCI Reset.
5104	PCI Reset	Disabled PCI Reset.
50A0	CPU DownCore Mode (only for Family15h CPU)	Enable CPU 2 cores only.
50A1	CPU DownCore Mode (only for Family15h CPU)	Enable CPU 4 cores only.
50A2	CPU DownCore Mode (only for Family15h CPU)	Enable CPU 8 cores only.
50A3	CPU DownCore Mode (only for Family15h CPU)	Enable CPU 12 cores only.
51A4	Cstate Mode	Set CPU Cstate to Disabled.
51A5	Cstate Mode	Set CPU Cstate to C6.
51A6	CPB Mode	Set CPB Mode to Disabled.
51A7	CPB Mode	Set CPB Mode to Auto.

Table 2-2. The IPMI Command Table

IPMI Command	Setup Option	Description
ipmitool raw 0x34 0xB1 <Byte1:4> Byte 1 - Power Management Enable(01h enable) Byte 2 - Power Capping Enable(01h enable) Byte 3 - Current Chassis Power Capping Value(Low Byte) Byte 4 - Current Chassis Power Capping Value(High Byte)	SET POWER MANAGEMENT BEHAVIOR	The setting controls PSU Power, its range limited in 450~2000 W. The value is sent to BMC by IPMI command and BMC will control PSU power. This setting can be seen when “Power Management” is selected to “APML” mode and the system board at location 2 in the chassis.
ipmitool raw 0xc 1 1 3 <IP Address>	IP Address	Use this option to input BMC LAN port IP address.
ipmitool raw 0xc 1 1 6 <Subnet Mask>	Subnet Mask	Use this option to input BMC LAN port subnet mask address.
ipmitool raw 0xc 1 1 12 <IP Address>	GateWay Address	Use this option to input BMC LAN port Gateway address.
ipmitool raw 0x30 1 Return: ID ipmitool raw 0x30 3 ID 0x11 0x2 0 0 0 1 <Delay Mode>	Power Staggering AC Recovery	Configures power recovery behavior. This item can be seen when “Remote on AC Power Loss” is selected in “Power On” or “Last State”. This parameter is only effective if the Power Policy is not set to always off. 0x00: Immediate Power On (No Delay) : Default 0x01: Auto (Random), the auto generated delay time must be in the range of Minimum Power On Delay and Maximum Power On Delay. 0x02: User Defined, the user defined delay time must be in the range of Minimum Power On Delay and Maximum Power On Delay.
ipmitool raw 0x30 1	Minimum Power	Configures time for power on delay,

IPMI Command	Setup Option	Description
Return: ID ipmitool raw 0x30 3 ID 0x11 0x4 0 0 0 1 <LSB timer> <HSB timer>	On Delay	the setting range of delay time is 0~255 Sec.
ipmitool raw 0x30 1 Return: ID ipmitool raw 0x30 3 ID 0x11 0x5 0 0 0 1 <LSB timer> <HSB timer>	Maximum Power On Delay	Configures time for power on delay, the setting range of delay time is 0~255 Sec.
ipmitool raw 0x30 1 Return: ID ipmitool raw 0x30 3 ID 0x11 0x3 0 0 0 1 <LSB timer> <HSB timer>	Power On Delay	Configures time for power on delay, the setting range of delay time is 0~255 Sec.
ipmitool raw 0x0a 0x42 Return: ID1 ID2 ipmitool raw 0x0a 0x47 ID1 ID2 0x43 0x4C 0x52 0xAA	Clear BMC System Event Log	Clears all events in the BMC Event Log.
ipmitool raw 0x34 0x11 Response: Byte 1 – completion code Byte 2 – Board ID	Get Board ID	Identify MLB's Board ID in chassis.

Table 2-3. The Power Management Settings

Setup Menu		Performance Settings		Power Optimized Settings	
		Option	D4 Token	Option	D4 Token
CPU Configuration	L3 Power Control	Enabled	4878	Disabled	4877
	DRAM Prefetcher	Enabled	48BA	Disabled	48B9
	Hardware Prefetcher	Enabled	0174	Disabled	0173
	Software Prefetcher	Enabled	48BE	Disabled	48BD
CPU Configuration ->Power Management	Power Management	Max. Performance	021F	OS Control P-State 4	0221 486A
CPU Configuration ->CPB Mode(Turbo Mode)	CPB Mode(Turbo Mode)	Auto	51A7	Disabled	51A6
SATA Configuration	Power Saving Features	Disabled	4891	Enabled	4892
	SATA-AHCI Ports Auto Clk Ctrl	Disabled	4871	Enabled	4872
	SATA-IDE Ports Auto Clk Ctrl	Disabled	4873	Enabled	4874
Hyper Transport Configuration	Coherent HT Link Speed	HT3	4888	HT1	4887
	Non-Coherent HT Link Speed	HT3 2600MHz	48A5	HT1 1200Mhz	48A2
	Non-Coherent HT Link Width	16 bits	48A7	8 bit	48A6
PCI Configuration -> Active State Power Management Configuration	PCI-E Slot ASPM	Disabled	5001	L0s & L1	5004
	Onboard LAN ASPM	Disabled	5021	L0s & L1	5024
	Mezzing Slot ASPM	Disabled	5091	L0s & L1	5094
	NB-SB Link ASPM	Disabled	4883	L1	4884

Installing System Components

Safety Instructions



WARNING: Working on systems that are still connected to a power supply can be extremely dangerous.



CAUTION: System components and electronic circuit boards can be damaged by discharge of static electricity.



CAUTION: Many repairs may only be done by a certified service technician. You should only perform troubleshooting and simple repairs as authorized in your product documentation, or as directed by the online or telephone service and support team. Damage due to servicing that is not authorized by Dell is not covered by your warranty. Read and follow the safety instructions that came with the product.

To avoid injury to yourself or damage to system, follow these guidelines:

- Always disconnect the system from the power outlet whenever you are working inside the system.
- If possible, wear a grounded wrist strap as you work inside the system. Or discharge any static electricity by touching the bare metal chassis of system case, or the bare metal body of any other grounded appliance.
- Hold electronic circuit boards by the edges only. Do not touch the components on the board unless it is necessary to do so. Do not flex or stress the circuit board.
- Leave all components inside the static-proof packaging until you are ready to use the component for the installation.

Recommended Tools

- #1 Phillips screwdriver
- #2 Phillips screwdrivers

Inside the System



CAUTION: Many repairs may only be done by a certified service technician. You should only perform troubleshooting and simple repairs as authorized in your product documentation, or as directed by the online or telephone service and support team. Damage due to servicing that is not authorized by Dell is not covered by your warranty. Read and follow the safety instructions that came with the product.



CAUTION: This system must be operated with the system cover installed to ensure proper cooling.



NOTE: The illustration in this section shows a system with 3.5" hard drives.

Figure 3-1. Inside the System

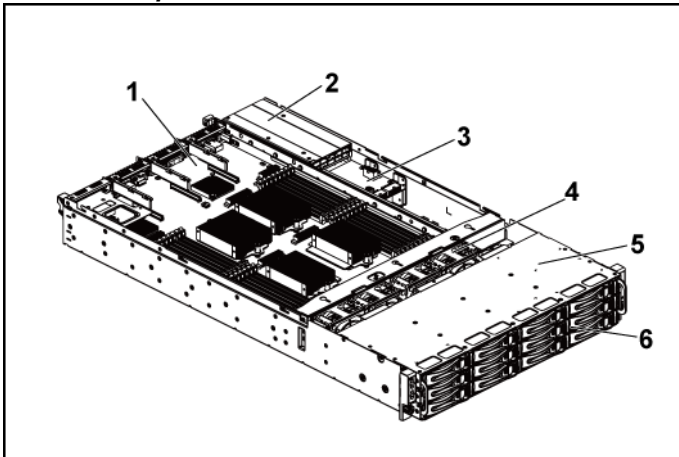

- | | | | |
|---|------------------------------|---|------------------|
| 1 | system-board assembly (2) | 2 | power supply (2) |
| 3 | power distribution board (2) | 4 | cooling fan (4) |
| 5 | hard-drive bay | 6 | hard drive (12) |

Hard Drives

The installation and removal procedures for the 3.5" hard drive and the 2.5" hard drive are similar. Following is an example showing the replacement procedure of a 3.5" hard drive.

Removing a Hard-Drive Blank



CAUTION: To maintain proper system cooling, all empty hard-drive bays must have drive blanks installed.



NOTE: This section is applicable to systems with hot-swappable hard drives only.

- 1 Using the release handle, pull the hard-drive blank out of the hard-drive bay. See Figure 3-2.

Figure 3-2. Removing or Installing a Hard-Drive Blank

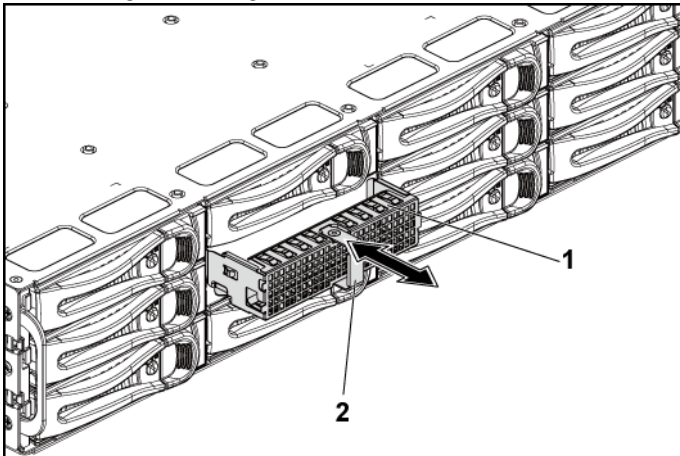

1 hard-drive blank

2 release handle

Installing a Hard-Drive Blank

- 1 Slide the hard-drive blank into the drive bay until the hard-drive blank makes contact with the backplane. See Figure 3-2.

Removing a Hard-Drive Carrier



CAUTION: Many repairs may only be done by a certified service technician. You should only perform troubleshooting and simple repairs as authorized in your product documentation, or as directed by the online or telephone service and support team. Damage due to servicing that is not authorized by Dell is not covered by your warranty. Read and follow the safety instructions that came with the product.

- 1 Turn the lock lever counterclockwise until it points to the unlock symbol.
- 2 Slide the release button to open the release handle. See Figure 3-3.
- 3 Using the release handle, pull the hard-drive carrier out of the hard-drive bay.



CAUTION: To maintain proper system cooling, all empty hard-drive bays must have drive blanks installed.

Figure 3-3. Removing and Installing a Hard-Drive Carrier

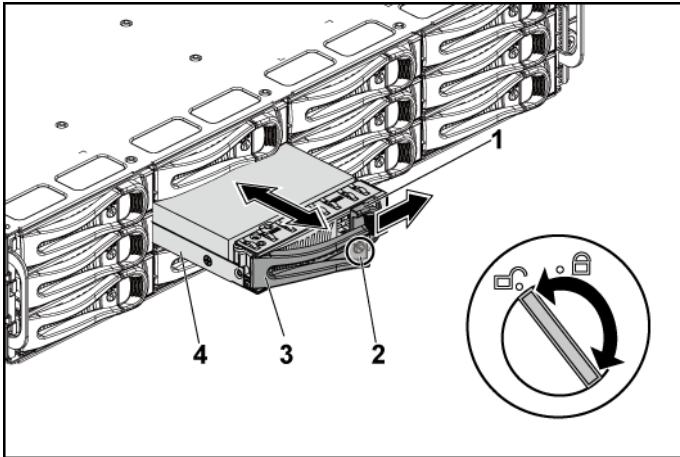

- | | | | |
|---|----------------|---|--------------------|
| 1 | release button | 2 | lock lever |
| 3 | release handle | 4 | hard-drive carrier |





Installing a Hard-Drive Carrier



CAUTION: Many repairs may only be done by a certified service technician. You should only perform troubleshooting and simple repairs as authorized in your product documentation, or as directed by the online or telephone service and support team. Damage due to servicing that is not authorized by Dell is not covered by your warranty. Read and follow the safety instructions that came with the product.

- 1 With the lever on the hard-drive carrier open, slide the hard-drive carrier into the drive bay until the hard-drive carrier makes contact with the backplane. See Figure 3-3.
- 2 Close the release handle to lock the hard drive in place.
- 3 Turn the lock lever clockwise to the lock symbol. See Figure 3-3.

Removing a Hard Drive From a Hard-Drive Carrier

-  **CAUTION:** Many repairs may only be done by a certified service technician. You should only perform troubleshooting and simple repairs as authorized in your product documentation, or as directed by the online or telephone service and support team. Damage due to servicing that is not authorized by Dell is not covered by your warranty. Read and follow the safety instructions that came with the product.
-  **CAUTION:** Combining SATA and SAS hard drives in the same system configuration is not supported.
-  **CAUTION:** Use only hard drives that have been tested and approved for use with the SAS/SATA backplane.
-  **CAUTION:** When installing a hard-drive carrier, ensure that the adjacent drives are fully installed. Inserting a hard-drive carrier and attempting to lock its handle next to a partially installed carrier can damage the partially installed carrier's shield spring and make it unusable.
-  **CAUTION:** To prevent data loss, ensure that your operating system supports hot-swappable drive installation. See the documentation supplied with the operating system.

- 1 Remove the four screws. See Figure 3-4.
- 2 Lift the hard drive out of the hard-drive carrier.

Figure 3-4. Removing and Installing a Hard Drive From the Hard-Drive Carrier

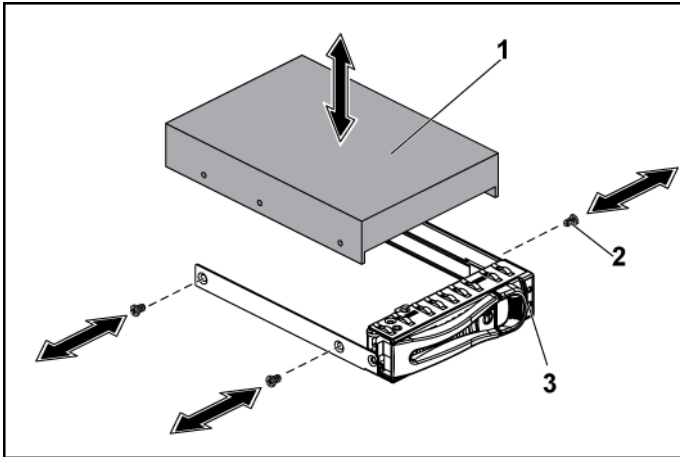

- | | | | |
|---|--------------------|---|-----------|
| 1 | hard drive | 2 | screw (4) |
| 3 | hard-drive carrier | | |

Installing a Hard Drive Into a Hard-Drive Carrier



CAUTION: Many repairs may only be done by a certified service technician. You should only perform troubleshooting and simple repairs as authorized in your product documentation, or as directed by the online or telephone service and support team. Damage due to servicing that is not authorized by Dell is not covered by your warranty. Read and follow the safety instructions that came with the product.

- 1 Place the hard drive into the hard-drive carrier. See Figure 3-4.
- 2 Secure the hard drive to the hard-drive carrier with four screws. See Figure 3-4.

Power Supplies



NOTE: The following table lists the maximum supported configuration where power supply redundancy is guaranteed.



NOTE: Configurations higher than indicated in the table may change the power supply mode to non-redundant. In non-redundant mode if the power requirement exceeds the installed system power capacity, the BIOS will throttle the CPUs. Also, if CPU Power Capping is enabled, then CPU throttling occurs on configurations that exceed the cap value.

Table 3-1. PSU and Motherboard Support Matrix for 3.5" HDD Backplane With CPLD / 2-Node Configuration

PSU	1 Motherboard	2 Motherboards
1100 W	Up to four 140W processors, sixteen 32G memory modules, and three 3.5" SAS hard drives	Up to two 115W processors/MLB, eight 32G memory modules/MLB, and four 3.5" SAS hard drives
1400 W	Up to four 140W processors, thirty-two 32G memory modules, and six 3.5" SAS hard drives	Up to four 85W processors/MLB, sixteen 32G memory modules/MLB, and four 3.5" SAS hard drives

Table 3-2. PSU and Motherboard Support Matrix for 3.5" HDD Backplane With Expander / 1-Node Configuration

PSU	1 Motherboard
1100 W	Up to four 85W processors/MLB, sixteen 32G memory modules/MLB, and twelve 3.5" SAS hard drives
1400 W	Up to four 140W processors, thirty-two 32G memory modules, and twelve 3.5" SAS hard drives



NOTE: The following table lists the detailed power supply configurations regarding to the different quantity of the DIMMs and HDDs.

Table 3-3. PSU Model and Quantity with CPLD / 2-Node Configuration

CPLD / 2-Node Configuration									
85W*4/Motherboard									
	DIMM (Quantity/MLB)	4	8	12	16	20	24	28	32
PSU (Model/Quantity)	HDD (Quantity/Chassis)	1400W*1	1400W*1	1400W*1	1400W*1	1100W*2	1100W*2	1100W*2	1100W*2
	2								
	4								
	6								
	8								
	10								
12									
115W*4/Motherboard									
	DIMM (Quantity/MLB)	4	8	12	16	20	24	28	32
PSU (Model/Quantity)	HDD (Quantity/Chassis)	1400W*1	1400W*1	1100W*2	1100W*2	1100W*2	1100W*2	1100W*2	1100W*2
	2								
	4								
	6								
	8								
	10								
12									

140W*4/Motherboard									
	DIMM (Quantity/MLB)	4	8	12	16	20	24	28	32
PSU (Model/Quantity)	HDD (Quantity/Chassis)	1100W*2	1100W*2	1100W*2	1100W*2	1100W*2	1100W*2	1100W*2	1400W*2
	2								
	4								
	6								
	8								
	10								
12									

Table 3-4. PSU Model and Quantity with Expander / 1-Node Configuration

Expander / 1-Node Configuration									
85W*4/Motherboard									
	DIMM (Quantity/MLB)	4	8	12	16	20	24	28	32
PSU (Model/Quantity)	HDD (Quantity/Chassis)	1100W*1	1100W*1	1100W*1	1100W*1	1100W*1	1100W*1	1100W*1	1100W*1
	2								
	4								
	6								
	8								
	10								
12									
115W*4/Motherboard									
	DIMM (Quantity/MLB)	4	8	12	16	20	24	28	32
PSU (Model/Quantity)	HDD (Quantity/Chassis)	1100W*1	1100W*1	1100W*1	1100W*1	1100W*1	1100W*1	1400W*1	1400W*1
	2								
	4								
	6								
	8								
	10								
12									

140W*4/Motherboard									
	DIMM (Quantity/MLB)	4	8	12	16	20	24	28	32
PSU (Model/Quantity)	HDD (Quantity/Chassis)	1100W*1	1100W*1	1100W*1	1100W*1	1400W*1	1400W*1	1400W*1	1400W*1
	2								
	4								
	6								
	8								
	10								
12									

Removing a Power Supply

CAUTION: Many repairs may only be done by a certified service technician. You should only perform troubleshooting and simple repairs as authorized in your product documentation, or as directed by the online or telephone service and support team. Damage due to servicing that is not authorized by Dell is not covered by your warranty. Read and follow the safety instructions that came with the product.

CAUTION: The System requires at least one power supply to operate normally.

- 1 Turn off the system, including any attached peripherals, and disconnect the system from the electrical outlet.
- 2 Disconnect the power cable from power source and the power supply.
- 3 Press the release lever and using the handle, slide the power supply out of the system. See Figure 3-5.

NOTE: Removing the power supply may require considerable force.

Figure 3-5. Removing and Installing a Power Supply

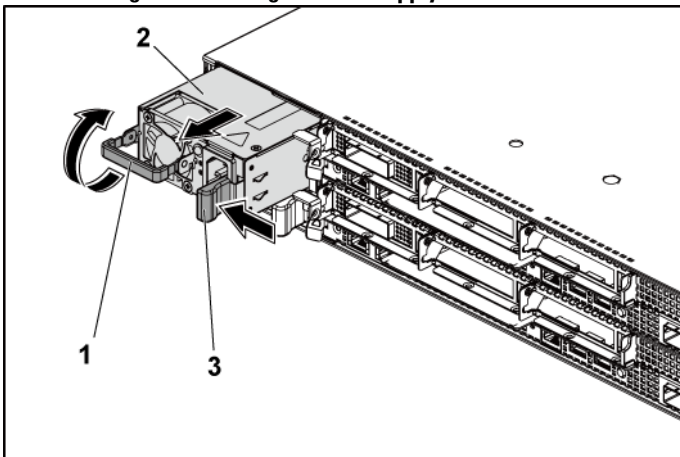

1 handle

2 power supply

3 release lever

Installing a Power Supply



CAUTION: Many repairs may only be done by a certified service technician. You should only perform troubleshooting and simple repairs as authorized in your product documentation, or as directed by the online or telephone service and support team. Damage due to servicing that is not authorized by Dell is not covered by your warranty. Read and follow the safety instructions that came with the product.



CAUTION: The System requires at least one power supply to operate normally.

- 1 Verify that both power supplies are of the same type and have the same maximum output power.



NOTE: The maximum output power is printed on the power supply label.

- 2 Slide the new power supply into the chassis until the power supply is fully seated and the release lever snaps into place. See Figure 3-5.
- 3 Connect the power cable to the power supply and plug the cable into a power outlet.



NOTE: When installing a new power supply in a system with two power supplies, allow several seconds for the system to recognize the power supply and determine its status.

System-Board Assembly

Removing a System-Board Assembly

△ CAUTION: Many repairs may only be done by a certified service technician. You should only perform troubleshooting and simple repairs as authorized in your product documentation, or as directed by the online or telephone service and support team. Damage due to servicing that is not authorized by Dell is not covered by your warranty. Read and follow the safety instructions that came with the product.

- 1 Recommend to turn off the system, including any attached peripherals, and disconnect the system from its electrical outlet.
- 2 Disconnect all the external cables from the system board.
- 3 Rotate down the retaining latches on both sides of the system-board assembly to the very bottom, and slide the system-board assembly out of the chassis. See Figure 3-6.

Figure 3-6. Removing and Installing a System-Board Assembly

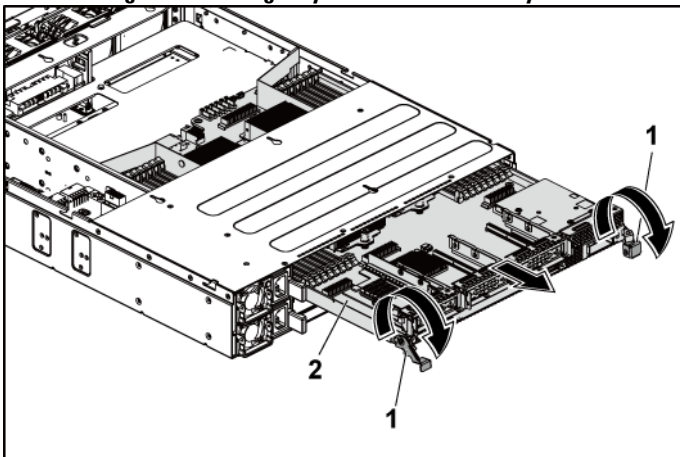

1 retaining latch (2)

2 system-board assembly

Installing a System-Board Assembly



CAUTION: Many repairs may only be done by a certified service technician. You should only perform troubleshooting and simple repairs as authorized in your product documentation, or as directed by the online or telephone service and support team. Damage due to servicing that is not authorized by Dell is not covered by your warranty. Read and follow the safety instructions that came with the product.

- 1 Slide the system-board assembly into the chassis until it snaps into place. See Figure 3-6.
- 2 Rotate the retaining latches on both sides of the system-board assembly upwards to the top to secure the system-board assembly with the chassis. See Figure 3-6.
- 3 Reconnect all the external cables to the system board.
- 4 Reconnect the system to its electrical outlet and turn on the system, including any attached peripherals.

Air Ducts

Removing the Air Duct



CAUTION: Many repairs may only be done by a certified service technician. You should only perform troubleshooting and simple repairs as authorized in your product documentation, or as directed by the online or telephone service and support team. Damage due to servicing that is not authorized by Dell is not covered by your warranty. Read and follow the safety instructions that came with the product.

- 1 Recommend to turn off the system, including any attached peripherals, and disconnect the system from its electrical outlet.
- 2 Remove the system-board assembly. See “Removing a System-Board Assembly” on page 115.
- 3 Squeeze and remove the rivets that secure the air ducts to the system-

board assembly and heat sinks. See Figure 3-7.

- 4 Gently lift air ducts out of the system-board assembly. See Figure 3-7.

Figure 3-7. Removing and Installing the Air Ducts

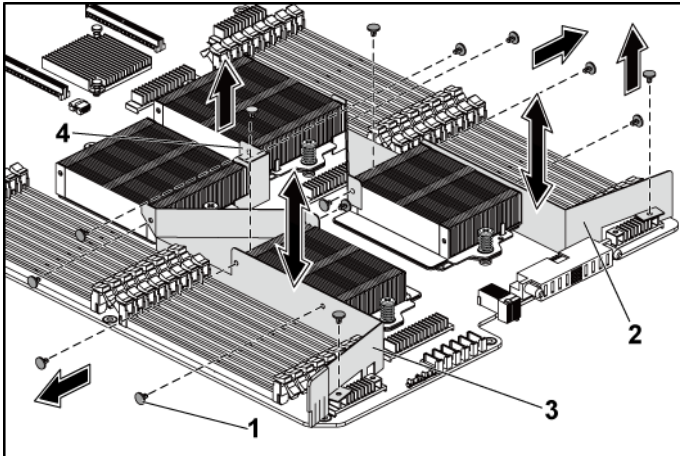

- | | | | |
|---|---|---|------------|
| 1 | rivet (6 for each of air ducts 1 and 2, and 2 for air duct 3) | 2 | air duct 2 |
| 3 | air duct 1 | 4 | air duct 3 |

Installing the Air Duct



CAUTION: Many repairs may only be done by a certified service technician. You should only perform troubleshooting and simple repairs as authorized in your product documentation, or as directed by the online or telephone service and support team. Damage due to servicing that is not authorized by Dell is not covered by your warranty. Read and follow the safety instructions that came with the product.



NOTE: The air duct configuration differs with the number of processors installed on the system board. For two-processor configuration, only the air duct 3 is installed between the processors 1 and 2; for four-processor configuration, the air ducts 1, 2 and 3 should all be installed. The Figure 3-7 shows the four-processor configuration.

- 1 Align the air ducts to the system-board assembly and heat sinks by the rivet holes. See Figure 3-7.
- 2 Replace the rivets to secure the air ducts to the system-board assembly and heat sinks. See Figure 3-7.

Heat Sinks

Removing the Heat Sink



CAUTION: Many repairs may only be done by a certified service technician. You should only perform troubleshooting and simple repairs as authorized in your product documentation, or as directed by the online or telephone service and support team. Damage due to servicing that is not authorized by Dell is not covered by your warranty. Read and follow the safety instructions that came with the product.

- 1 Recommend to turn off the system, including any attached peripherals, and disconnect the system from its electrical outlet.
- 2 Remove the system-board assembly. See "Removing a System-Board Assembly" on page 115.
- 3 Remove the air duct(s). See "Removing the Air Duct" on page 116.



WARNING: The heat sink may be hot to touch for some time after the system has been powered down. Allow the heat sink to cool before removing it.



CAUTION: Never remove the heat sink from a processor unless you intend to remove the processor. The heat sink is necessary for proper thermal conditions.

- 4 Using a Phillips screwdriver, loosen one of the heat-sink retention

screws. See Figure 3-8.

Wait for 30 seconds for the heat sink to loosen from the processor.

- 5 Remove the other heat-sink retention screw.
- 6 Gently lift the heat sink off the processor and set the heat sink aside with thermal grease side facing up.

Figure 3-8. Removing and Installing the Heat Sink

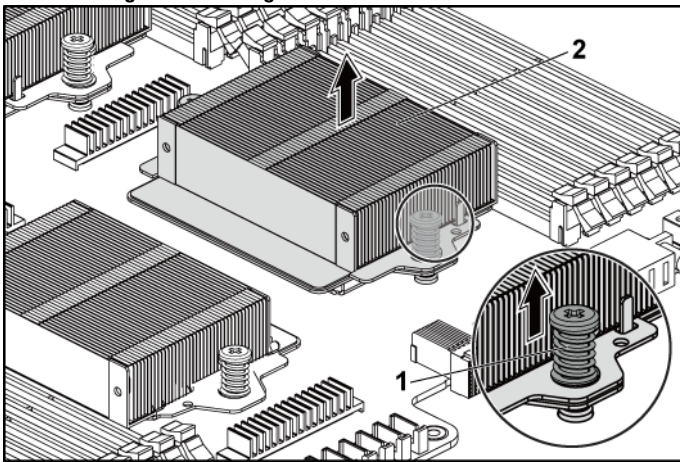

1 screw (2)

2 heat sink

Installing the Heat Sink



CAUTION: Many repairs may only be done by a certified service technician. You should only perform troubleshooting and simple repairs as authorized in your product documentation, or as directed by the online or telephone service and support team. Damage due to servicing that is not authorized by Dell is not covered by your warranty. Read and follow the safety instructions that came with the product.

- 1 Using a clean lint-free cloth, remove thermal grease from the heat sink.
- 2 Apply new thermal grease evenly to the center of the top new processor.



CAUTION: Using excess thermal grease can cause grease to contact the processor shield, which can cause contamination of the processor socket.

- 3 Place the heat sink on the processor. Make sure the guide pin is inserted through the slot of the heat sink. See Figure 3-8.
- 4 Using a Phillips screwdriver, tighten the two heat-sink retention screws.
- 5 Install the system-board assembly. See "Installing a System-Board Assembly" on page 116.
- 6 Reconnect the system to its electrical outlet and turn on the system, including any attached peripherals.
- 7 Install the air duct(s). See "Installing the Air Duct" on page 117.

Processors

The following tables list the limited configurations of the C6145 system for proper thermal conditions:

Table 3-5. Limited Configuration Matrix for Proper Thermal Condition on 2-Node System

Processor (G34 TDP)	Hard Drive QTY	Note
85 W	3.5" x12	No PCI-E card on PCI-E slot 2
	2.5" x24	Support PCI-E cards on PCI-E slot 2 and slot 3
85 W	3.5" x8	3.5" hard-drive blank and carrier should be put on the four slots in the second row of the hard-drive slots as Figure 1-1.
	2.5" x18	2.5" hard-drive blank and carrier should be put on the hard-drive ID 10-12 and 22-24 as Figure 1-5.
115 W	3.5" x8	Support PCI-E cards on PCI-E slot 2 and slot 3
	2.5" x18	3.5" hard-drive blank and carrier should be put on the four slots in the second row of the hard-drive slots as Figure 1-1. 2.5" hard-drive blank and carrier should be put on the hard-drive ID 10-12 and 22-24 as Figure 1-5.
140 W	3.5" x8	No PCI-E card on PCI-E slot 2. 3.5" hard-drive blank and carrier should be put on the four slots in the second row of the hard-drive slots as Figure 1-1 and allow max ambient 30°C.

Table 3-6. Limited Configuration Matrix for Proper Thermal Condition on 1-Node System

Processor (G34 TDP)	Hard Drive QTY	Note
85 W	3.5" x12	
	2.5" x24	
115 W	3.5" x12	
	2.5" x24	
140 W	3.5" x8	3.5" hard-drive blank and carrier should be put on the four slots in the second row of the hard-drive slots as Figure 1-3 and allow max ambient 30°C.

Removing a Processor



CAUTION: Many repairs may only be done by a certified service technician. You should only perform troubleshooting and simple repairs as authorized in your product documentation, or as directed by the online or telephone service and support team. Damage due to servicing that is not authorized by Dell is not covered by your warranty. Read and follow the safety instructions that came with the product.



NOTE: If you are upgrading your processors, prior to upgrading your system, download and install the latest system BIOS version from support.dell.com. Follow the instructions included in the file downloaded to install the update on your system.

- 1 Recommend to turn off the system, including any attached peripherals, and disconnect the system from its electrical outlet.
- 2 Remove the system-board assembly. See "Removing a System-Board Assembly" on page 115.
- 3 Remove the heat sink, see "Removing the Heat Sink" on page 118.



CAUTION: The processor is held in its socket under strong pressure. Be aware that the release lever can spring up suddenly if not firmly grasped.

- 4 Position your thumb firmly over the processor socket-release lever and release the lever from the locked position. Rotate the lever 90 degrees

- upward until the processor is released from the socket. See Figure 3-9.
- 5 Rotate the processor shield upward and out of the way. See Figure 3-9.
 - 6 Lift the processor out of the socket and leave the socket-release lever up so that the socket is ready for the new processor.

CAUTION: Be careful not to bend any of the pins on the ZIF socket when removing the processor. Bending the pins can permanently damage the system board. Be sure to properly align the processor notch to the socket and insert straight down. Do not move from side to side.

Figure 3-9. Removing and Installing a Processor

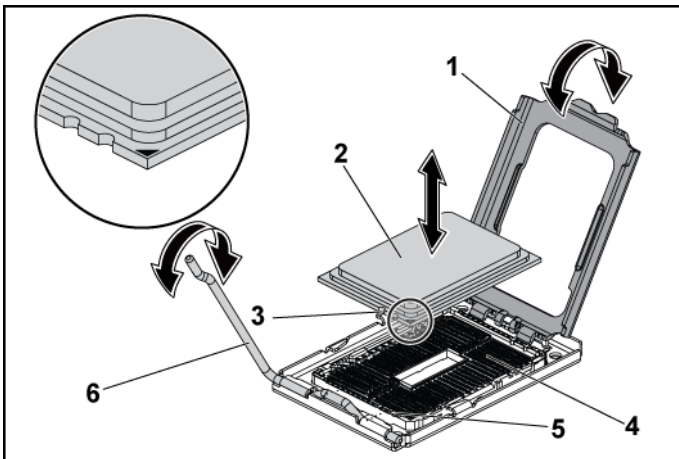

- | | | | |
|---|------------------------|---|----------------------|
| 1 | processor shield | 2 | processor |
| 3 | notch in processor (2) | 4 | ZIF socket |
| 5 | socket key (2) | 6 | socket-release lever |

Installing a Processor



CAUTION: Many repairs may only be done by a certified service technician. You should only perform troubleshooting and simple repairs as authorized in your product documentation, or as directed by the online or telephone service and support team. Damage due to servicing that is not authorized by Dell is not covered by your warranty. Read and follow the safety instructions that came with the product.



NOTE: When installing only one processor, the processor must be installed in the processor0 (for the socket location, see “System Board Connectors” on page 229).



NOTE: If you are upgrading your processors, prior to upgrading your system, download and install the latest system BIOS version from support.dell.com. Follow the instructions included in the file download to install the update on your system.

1. Unpack the processor if it has not been used previously.
If the processor has already been used, remove any thermal grease from the top of the processor using a lint-free cloth.
2. Align the processor with the socket keys on the ZIF socket. See Figure 3-9.



CAUTION: Positioning the processor incorrectly can permanently damage the system board or the processor. Be careful not to bend the pins in the ZIF socket.

3. With the release lever on the processor socket in the open position, align the processor with the socket keys and set the processor lightly in the socket. See Figure 3-9.
-  **CAUTION:** Do not use force to seat the processor. When the processor is positioned correctly, it engages easily into the socket.
4. Close the processor shield.
 5. Rotate the socket release lever down until it snaps into place.
 6. Using a clean lint-free cloth, remove the thermal grease from the heat sink.
 7. Apply thermal grease evenly to the center of the top of the new

processor.



CAUTION: Using excess thermal grease can cause grease to contact the processor shield, which can cause contamination of the processor socket.

- 8 Place the heat sink on the processor. See Figure 3-8.
- 9 Using a Phillips screwdriver, tighten the heat-sink retention screws. See Figure 3-8.
- 10 Install the air duct(s). See "Installing the Air Duct" on page 117.
- 11 Install the system-board assembly. See "Installing a System-Board Assembly" on page 116.
- 12 Reconnect the system to its electrical outlet and turn on the system, including any attached peripherals.
- 13 Press <F2> to enter the System Setup program, and check that the processor information matches the new system configuration. See "System Setup Options at Boot" on page 46.

Expansion-Card Assembly and Expansion Card

Removing the Expansion Card



CAUTION: Many repairs may only be done by a certified service technician. You should only perform troubleshooting and simple repairs as authorized in your product documentation, or as directed by the online or telephone service and support team. Damage due to servicing that is not authorized by Dell is not covered by your warranty. Read and follow the safety instructions that came with the product.

- 1 Recommend to turn off the system, including any attached peripherals, and disconnect the system from its electrical outlet.
- 2 Remove the system-board assembly. See "Removing a System-Board Assembly" on page 115.
- 3 Remove the three screws that secure the expansion-card assembly. See

Figure 3-10.

- 4 Lift the expansion-card assembly out of the system-board assembly.
See Figure 3-10.

Figure 3-10. Removing the Expansion-Card Assembly

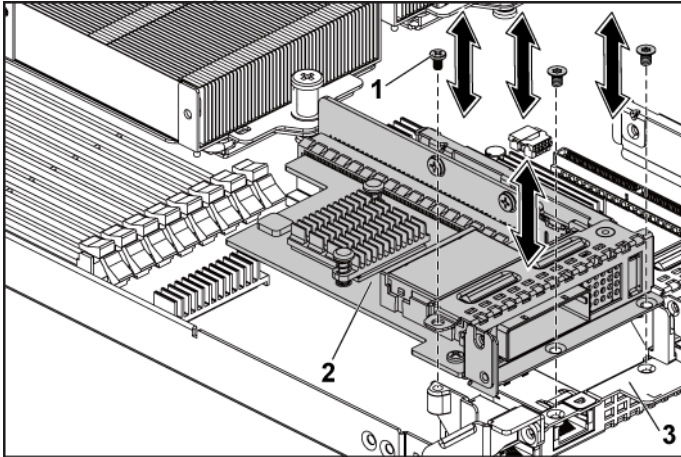

- 1 screw (3)
- 2 expansion-card assembly
- 3 system-board assembly

- 5 Remove the screw that secures the expansion card to the expansion-card cage.
- 6 Grasp the expansion card by its edges, and carefully remove it from the expansion-card connector.
- 7 If you are removing the card permanently, install a metal filler bracket over the empty expansion slot opening, and close the expansion-card latch.



NOTE: You must install a filler bracket over an empty expansion slot to maintain Federal Communications Commission (FCC) certification of the system. The brackets also keep dust and dirt out of the system and aid in proper cooling and airflow inside the system.

Figure 3-11. Removing the Expansion Card

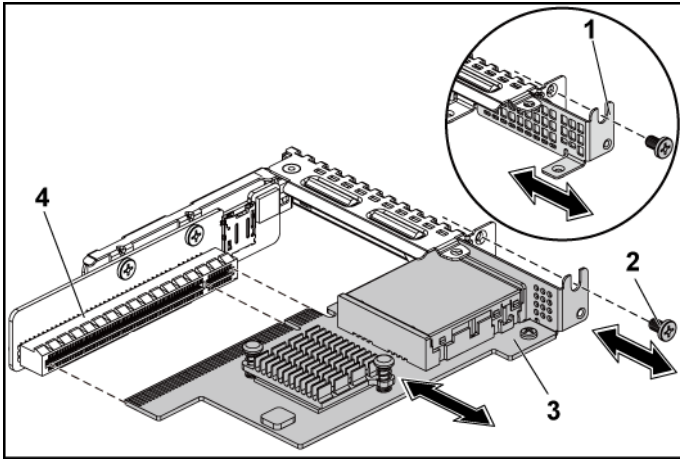

- | | | | |
|---|----------------------|---|--------------------------|
| 1 | metal filler bracket | 2 | screw |
| 3 | expansion card | 4 | expansion-card connector |

Installing the Expansion Card



CAUTION: Many repairs may only be done by a certified service technician. You should only perform troubleshooting and simple repairs as authorized in your product documentation, or as directed by the online or telephone service and support team. Damage due to servicing that is not authorized by Dell is not covered by your warranty. Read and follow the safety instructions that came with the product.



CAUTION: Expansion cards can only be installed in the slots on the expansion-card riser. Do not attempt to install expansion cards directly into the riser connector on the system board.

1. Unpack the expansion card and prepare it for installation. For instructions, see the documentation accompanying the card.
2. Recommend to turn off the system, including any attached peripherals, and disconnect the system from its electrical outlet.

- 3 Remove the system-board assembly. See "Removing a System-Board Assembly" on page 115.
- 4 Remove the three screws that secure the expansion-card assembly. See Figure 3-10.
- 5 Lift the expansion-card assembly away from the system-board assembly. See Figure 3-10.
- 6 Grasp the filler bracket by its edges, and carefully remove it from the expansion-card connector. See Figure 3-11.



NOTE: Keep this bracket in case you need to remove the expansion card. Filler brackets must be installed over empty expansion-cards slots to maintain FCC certification of the system. The brackets also keep dust and dirt out of the system and aid in proper cooling and airflow inside the system.

- 7 Holding the card by its edges, position the card so that the card-edge connector aligns with the expansion-card connector on the expansion-card assembly.
- 8 Insert the card-edge connector firmly into the expansion-card connector until the card is fully seated.
- 9 Replace the screw securing the expansion card.
- 10 Place the expansion-card assembly into the system-board assembly.
- 11 Replace the three screws that secure the expansion-card assembly.
- 12 Install the system-board assembly. See "Installing a System-Board Assembly" on page 116.
- 13 Reconnect the system to its electrical outlet and turn on the system, including any attached peripherals.

LSI 9260-8i Card



NOTE: The LSI 9260-8i card assembly should include the BBU interposer card which is connected to the RAID battery. The illustrations in this section are just for your removal and installation reference. For more information of the RAID battery, see "LSI 9260-8i RAID Battery (Optional)" on page 135.

Removing the LSI 9260-8i Card



CAUTION: Many repairs may only be done by a certified service technician. You should only perform troubleshooting and simple repairs as authorized in your product documentation, or as directed by the online or telephone service and support team. Damage due to servicing that is not authorized by Dell is not covered by your warranty. Read and follow the safety instructions that came with the product.

- 1 Remove the system-board assembly. See "Removing a System-Board Assembly" on page 115.
- 2 Disconnect the two SAS/SGPIO cables connecting to the LSI 9260-8i card assembly.
- 3 Remove the three screws that secure the LSI 9260-8i card assembly. See Figure 3-12.
- 4 Lift the LSI 9260-8i card assembly out of the system-board assembly. See Figure 3-12.

Figure 3-12. Removing the LSI 9260-8i Card Assembly

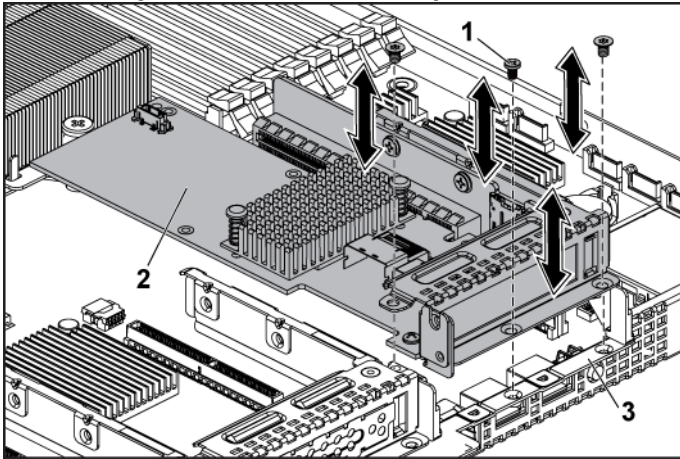

- 1 screw (3)
- 2 LSI 9260-8i-card assembly
- 3 system-board assembly

- 5 Remove the screw securing the LSI 9260-8i card.
- 6 Grasp the LSI 9260-8i card by its edges, and carefully remove it from the expansion-card connector.

Figure 3-13. Removing the LSI 9260-8i Card

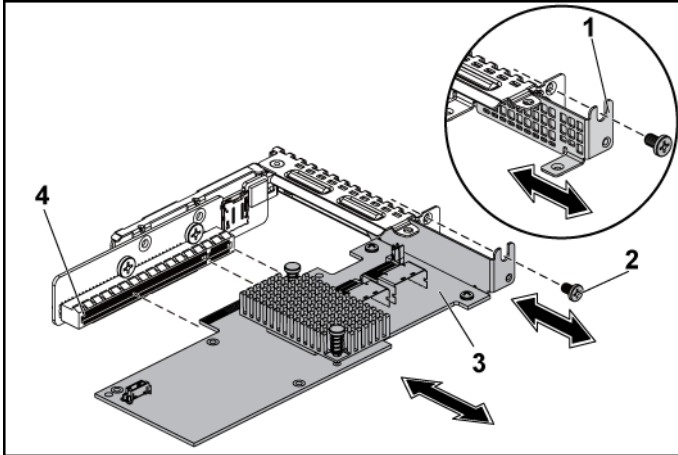

- | | | | |
|---|---------------------------|---|--------------------------|
| 1 | expansion-card slot cover | 2 | screw |
| 3 | LSI 9260-8i card | 4 | expansion-card connector |

7 If you are removing the card permanently, install a metal filler bracket over the empty expansion slot opening, and close the expansion-card latch.



NOTE: You must install a filler bracket over an empty expansion slot to maintain Federal Communications Commission (FCC) certification of the system. The brackets also keep dust and dirt out of the system and aid in proper cooling and airflow inside the system.

- 8 Remove the BBU interposer card by unscrewing the three screws.
- 9 Lift the BBU interposer card away from the LSI9260-8i card.
- 10 Disconnect the RAID battery cable from the BBU interposer card.

Installing the LSI 9260-8i Card



CAUTION: Many repairs may only be done by a certified service technician. You should only perform troubleshooting and simple repairs as authorized in your product documentation, or as directed by the online or telephone service and support team. Damage due to servicing that is not authorized by Dell is not covered by your warranty. Read and follow the safety instructions that came with the product.



CAUTION: Expansion cards can only be installed in the slots on the expansion-card riser. Do not attempt to install expansion cards directly into the riser connector on the system board.

- 1 Unpack the LSI 9260-8i card and prepare it for installation. For instructions, see the documentation accompanying the card.
- 2 Recommend to turn off the system, including any attached peripherals, and disconnect the system from its electrical outlet.
- 3 Remove the system-board assembly. See "Removing a System-Board Assembly" on page 115.
- 4 Connect the RAID battery cable to the BBU interposer card. See Figure 3-14.
- 5 Attach the BBU interposer card onto the LSI 9260-8i card by securing the three screws coming with the RAID battery. For the installation steps of the RAID battery, see "LSI 9260-8i RAID Battery (Optional)" on page 135.
- 6 Remove the screw securing the filler bracket. Grasp the filler bracket by its edges, and carefully remove it from the expansion-card connector.



NOTE: Keep this bracket in case you need to remove the expansion card. Filler brackets must be installed over empty expansion-cards slots to maintain FCC certification of the system. The brackets also keep dust and dirt out of the system and aid in proper cooling and airflow inside the system.

- 7 Connect the two SAS/SGPIO cables to the LSI 9260-8i card assembly.

See Figure 3-14.

- 8 Holding the card by its edges, position the card so that the card-edge connector aligns with the expansion-card connector.
- 9 Insert the card-edge connector firmly into the expansion-card connector until the card is fully seated.
- 10 Replace the screw securing the LSI 9260-8i card.
- 11 Place the LSI 9260-8i card assembly into the system-board assembly.
- 12 Replace the three screws that secure the LSI 9260-8i card assembly.
- 13 Install the system-board assembly. See "Installing a System-Board Assembly" on page 116.

Cable Routing for LSI 9260-8i Card

- 1 Connect the mini-SAS&SGPIO cable to the LSI 9260-8i card, and connect the other end of the cable to the corresponding connectors on the system board. Make sure the cables should go through the cable clip ring. See Figure 3-14.
- 2 Connect the RAID battery cable to the BBU interposer card on the LSI 9260-8i card, and connect the other end of the cable to the corresponding connector on the RAID battery.



NOTE: When connecting the RAID battery cable, the BBU interposer card should be installed on the LSI 9260-8i card. The BBU interposer card in the figure below is just for you reference.

Figure 3-14. Cable Routing for LSI 9260-8i Card

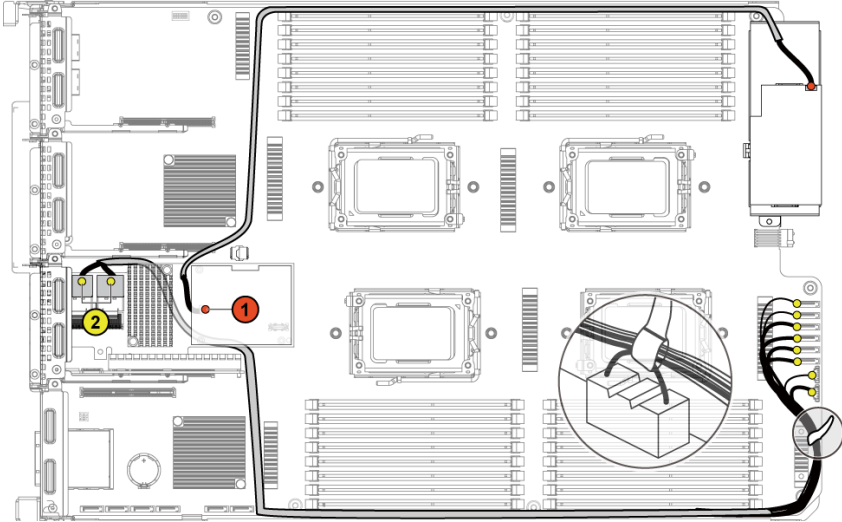

Item	Cable	From (LSI 9260-8i Card)	To (RAID Battery and HDD to Backplane SATAII Connectors)
1	RAID battery cable	RAID battery connector (J4)	RAID battery connector
2	SAS/SGPIO cable	Mini-SAS connector A & Mini-SAS connector B	SATAII connectors 0~5 and SGPIO A&B

LSI 9260-8i RAID Battery (Optional)

Removing the LSI 9260-8i RAID Battery



CAUTION: Many repairs may only be done by a certified service technician. You should only perform troubleshooting and simple repairs as authorized in your product documentation, or as directed by the online or telephone service and support team. Damage due to servicing that is not authorized by Dell is not covered by your warranty. Read and follow the safety instructions that came with the product.



NOTE: The information in this section applies only to systems intalled with the LSI 9260-8i card.

- 1 Recommend to turn off the system, including any attached peripherals, and disconnect the system from the electrical outlet.
- 2 Remove the system-board assembly. See “Removing a System-Board Assembly” on page 115.
- 3 Disconnect the cable connecting to the LSI 9260-8i card.
- 4 Press the LSI 9260-8i RAID battery latch and lift the RAID battery to release it from the LSI 9260-8i RAID battery carrier. See Figure 3-15.
- 5 Slide and lift the LSI 9260-8i RAID battery away from the LSI 9260-8i RAID battery carrier. See Figure 3-15.

Figure 3-15. Removing and Installing the LSI 9260-8i RAID Battery

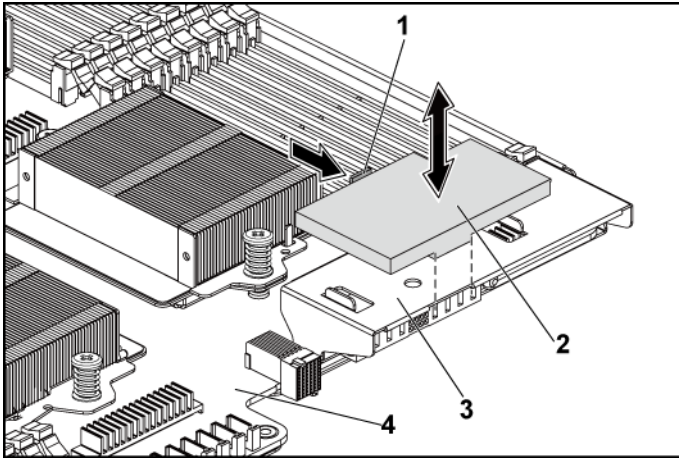

- | | | | |
|---|----------------------------------|---|--------------------------|
| 1 | RAID battery latch | 2 | LSI 9260-8i RAID battery |
| 3 | LSI 9260-8i RAID battery carrier | 4 | system-board assembly |

Installing the LSI 9260-8i RAID Battery

- 1 Insert the LSI 9260-8i RAID battery into the battery carrier until the RAID battery latch locks into place. See Figure 3-15.
- 2 Connect the cable connecting to the LSI 9260-8i card.
- 3 Install the system-board assembly. See “Installing a System-Board Assembly” on page 116.
- 4 Reconnect the system to the electrical outlet and turn the system on, including any attached peripherals.

Removing the LSI 9260-8i RAID Battery Carrier



CAUTION: Many repairs may only be done by a certified service technician. You should only perform troubleshooting and simple repairs as authorized in your product documentation, or as directed by the online or telephone service and support team. Damage due to servicing that is not authorized by Dell is not covered by your warranty. Read and follow the safety instructions that came with the product.



NOTE: The information in this section applies only to systems with the optional RAID controller card.

- 1 Recommend to turn off the system, including any attached peripherals, and disconnect the system from the electrical outlet.
- 2 Remove the system-board assembly. See “Removing a System-Board Assembly” on page 115.
- 3 Remove the LSI 9260-8i RAID battery. See “Removing the LSI 9260-8i RAID Battery” on page 135.
- 4 Remove the two screws securing the LSI 9260-8i RAID battery carrier to the interposer extender, and lift the LSI 9260-8i RAID battery carrier away from the interposer extender. See Figure 3-16.

Figure 3-16. Removing and Installing the LSI 9260-8i RAID Battery Carrier

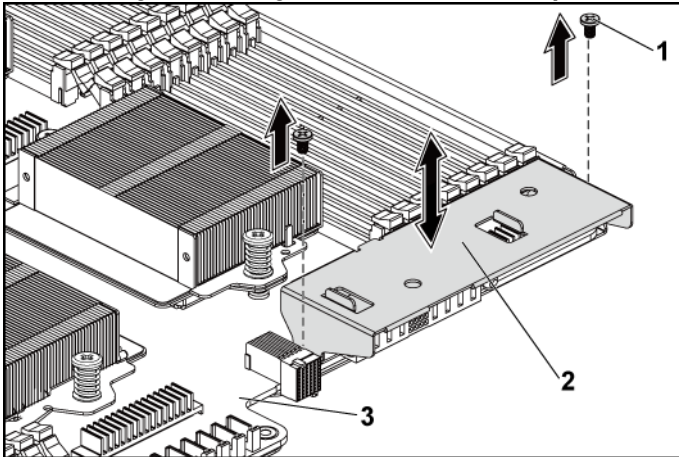

- 1 screw (2)
- 2 LSI 9260-8i RAID battery carrier
- 3 system-board assembly

Installing the LSI 9260-8i RAID Battery Carrier

- 1 Place the LSI 9260-8i RAID battery carrier in position on the interposer extender. See Figure 3-16.
- 2 Replace the screws securing the LSI 9260-8i RAID battery carrier to the interposer extender. See Figure 3-16.
- 3 Install the LSI 9260-8i RAID battery into the LSI 9260-8i RAID battery carrier. See “Installing the LSI 9260-8i RAID Battery” on page 136.
- 4 Install the system-board assembly. See “Installing a System-Board Assembly” on page 116.
- 5 Reconnect the system to the electrical outlet and turn the system on, including any attached peripherals.

LSI 9265-8i Card



NOTE: The LSI 9265-8i card assembly should include the BBU interposer card which is connected to the RAID battery. The illustrations in this section are just for your removal and installation reference. For more information of the RAID battery, see "LSI 9265-8i RAID Battery (Optional)" on page 145.

Removing the LSI 9265-8i Card



CAUTION: Many repairs may only be done by a certified service technician. You should only perform troubleshooting and simple repairs as authorized in your product documentation, or as directed by the online or telephone service and support team. Damage due to servicing that is not authorized by Dell is not covered by your warranty. Read and follow the safety instructions that came with the product.

- 1 Remove the system-board assembly. See "Removing a System-Board Assembly" on page 115.
- 2 Disconnect the two SAS/SGPIO cables connecting to the LSI 9265-8i card assembly.
- 3 Remove the three screws that secure the LSI 9265-8i card assembly. See Figure 3-17.

- 4 Lift the LSI 9265-8i card assembly out of the system-board assembly.
See Figure 3-17.

Figure 3-17. Removing the LSI 9265-8i Card Assembly

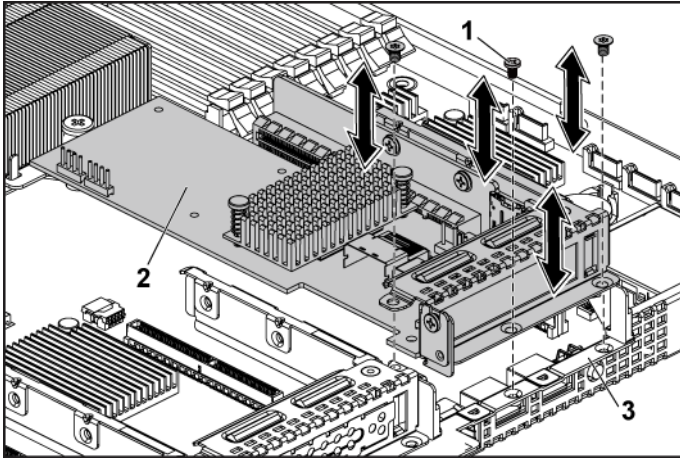

- 1 screw (3)
- 2 LSI 9265-8i-card assembly
- 3 system-board assembly

- 5 Remove the screw securing the LSI 9265-8i card. See Figure 3-18.
- 6 Grasp the LSI 9265-8i card by its edges, and carefully remove it from the expansion-card connector. See Figure 3-18.

Figure 3-18. Removing the LSI 9265-8i Card

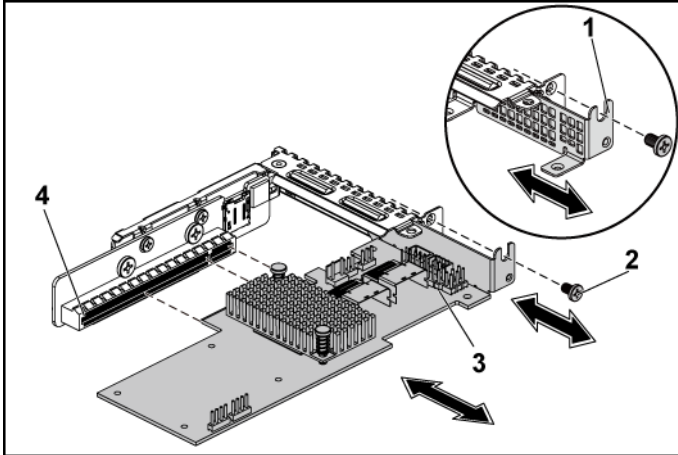

- | | | | |
|---|---------------------------|---|--------------------------|
| 1 | expansion-card slot cover | 2 | screw |
| 3 | LSI 9265-8i card | 4 | expansion-card connector |
- 7 If you are removing the card permanently, install a metal filler bracket over the empty expansion slot opening, and close the expansion-card latch.



NOTE: You must install a filler bracket over an empty expansion slot to maintain Federal Communications Commission (FCC) certification of the system. The brackets also keep dust and dirt out of the system and aid in proper cooling and airflow inside the system.

- 8 Remove the BBU interposer card by unscrewing the three screws.
- 9 Lift the BBU interposer card away from the LSI9265-8i card.
- 10 Disconnect the RAID battery cable from the BBU interposer card.

Installing the LSI 9265-8i Card



CAUTION: Many repairs may only be done by a certified service technician. You should only perform troubleshooting and simple repairs as authorized in your product documentation, or as directed by the online or telephone service and support team. Damage due to servicing that is not authorized by Dell is not covered by your warranty. Read and follow the safety instructions that came with the product.



CAUTION: Expansion cards can only be installed in the slots on the expansion-card riser. Do not attempt to install expansion cards directly into the riser connector on the system board.

- 1 Unpack the LSI 9265-8i card and prepare it for installation. For instructions, see the documentation accompanying the card.
- 2 Recommend to turn off the system, including any attached peripherals, and disconnect the system from its electrical outlet.
- 3 Remove the system-board assembly. See "Removing a System-Board Assembly" on page 115.
- 4 Connect the RAID battery cable to the BBU interposer card. See Figure 3-19.
- 5 Attach the BBU interposer card onto the LSI 9265-8i card by securing the three screws coming with the RAID battery. For the installation steps of the RAID battery, see "LSI 9265-8i RAID Battery (Optional)" on page 145.
- 6 Remove the screw securing the filler bracket. Grasp the filler bracket by its edges, and carefully remove it from the expansion-card connector.



NOTE: Keep this bracket in case you need to remove the expansion card. Filler brackets must be installed over empty expansion-cards slots to maintain FCC certification of the system. The brackets also keep dust and dirt out of the system and aid in proper cooling and airflow inside the system.

- 7 Connect the two SAS/SGPIO cables to the LSI 9265-8i card assembly.

See Figure 3-19.

- 8 Holding the card by its edges, position the card so that the card-edge connector aligns with the expansion-card connector.
- 9 Insert the card-edge connector firmly into the expansion-card connector until the card is fully seated.
- 10 Replace the screw securing the LSI 9265-8i card.
- 11 Place the LSI 9265-8i card assembly into the system-board assembly.
- 12 Replace the three screws that secure the LSI 9265-8i card assembly.
- 13 Install the system-board assembly. See "Installing a System-Board Assembly" on page 116.

Cable Routing for LSI 9265-8i Card

- 1 Connect the mini-SAS&SGPIO cable to the LSI 9265-8i card, and connect the other end of the cable to the corresponding connectors on the system board. Make sure the cables should go through the cable clip ring. See Figure 3-19.
- 2 Connect the RAID battery cable to the BBU interposer card on the LSI 9265-8i card, and connect the other end of the cable to the corresponding connector on the RAID battery.



NOTE: When connecting the RAID battery cable, the BBU interposer card should be installed on the LSI 9265-8i card. The BBU interposer card in the figure below is just for you reference.

Figure 3-19. Cable Routing for LSI 9265-8i Card

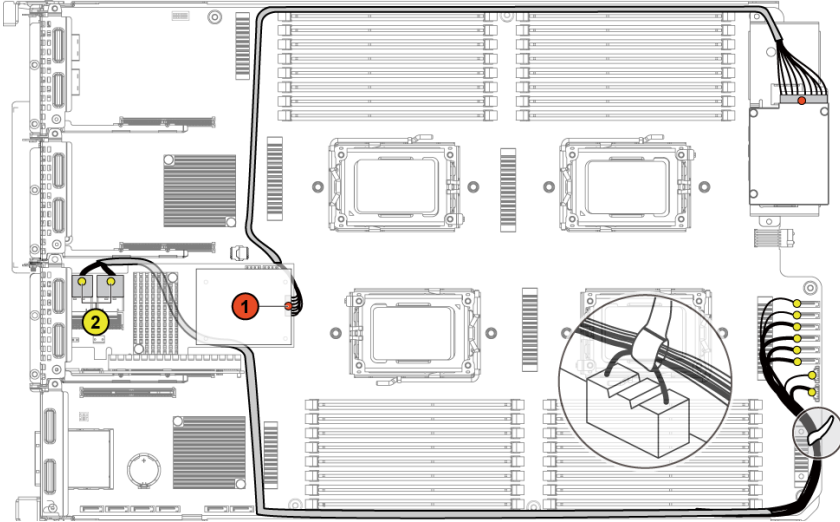

Item	Cable	From (LSI 9265-8i Card)	To (RAID Battery and HDD to Backplane SATAII Connectors)
❶	RAID battery cable	RAID battery connector (J4)	RAID battery connector
❷	SAS/SGPIO cable	Mini-SAS connector A & Mini-SAS connector B	SATAII connectors 0~5 and SGPIO A&B

LSI 9265-8i RAID Battery (Optional)

Removing the LSI 9265-8i RAID Battery Assembly



CAUTION: Many repairs may only be done by a certified service technician. You should only perform troubleshooting and simple repairs as authorized in your product documentation, or as directed by the online or telephone service and support team. Damage due to servicing that is not authorized by Dell is not covered by your warranty. Read and follow the safety instructions that came with the product.



NOTE: The information in this section applies only to systems with the optional RAID controller card.

- 1 Recommend to turn off the system, including any attached peripherals, and disconnect the system from the electrical outlet.
- 2 Remove the system-board assembly. See “Removing a System-Board Assembly” on page 115.
- 3 Disconnect the cable connecting to the LSI 9265-8i card.
- 4 Remove the two screws securing the LSI 9265-8i RAID battery assembly to the system-board assembly, and lift the LSI 9265-8i RAID battery assembly away from the system-board assembly. See Figure 3-20.

Figure 3-20. Removing and Installing the LSI 9265-8i RAID Battery Assembly

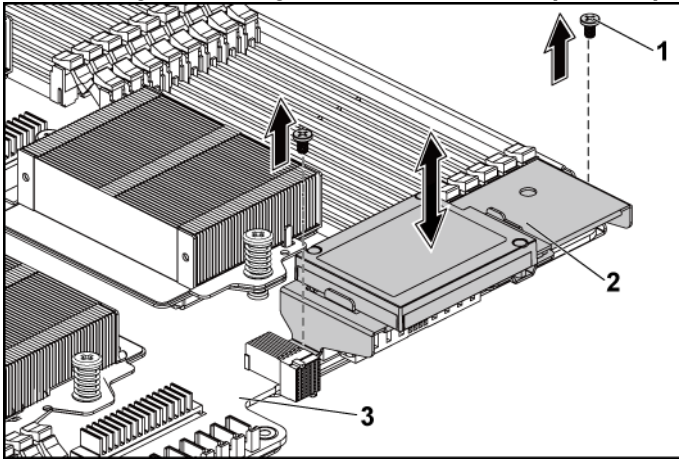

- 1 screw (2)
- 2 LSI 9265-8i RAID battery assembly
- 3 system-board assembly

Installing the LSI 9265-8i RAID Battery Assembly

- 1 Place the LSI 9265-8i RAID battery assembly in position on the system-board assembly. See Figure 3-20.
- 2 Replace the screws securing the LSI 9265-8i RAID battery assembly to the system-board assembly. See Figure 3-20.
- 3 Connect the cable connecting to the LSI 9265-8i card.
- 4 Install the system-board assembly. See “Installing a System-Board Assembly” on page 116.
- 5 Reconnect the system to the electrical outlet and turn the system on, including any attached peripherals.

Removing the LSI 9265-8i RAID Battery



CAUTION: Many repairs may only be done by a certified service technician. You should only perform troubleshooting and simple repairs as authorized in your product documentation, or as directed by the online or telephone service and support team. Damage due to servicing that is not authorized by Dell is not covered by your warranty. Read and follow the safety instructions that came with the product.



NOTE: The information in this section applies only to systems intalled with the LSI 9265-8i card.

- 1 Recommend to turn off the system, including any attached peripherals, and disconnect the system from the electrical outlet.
- 2 Remove the system-board assembly. See “Removing a System-Board Assembly” on page 115.
- 3 Disconnect the cable connecting to the LSI 9265-8i card.
- 4 Remove the LSI 9265-8i RAID battery assembly from the system-board assembly. See “Removing the LSI 9265-8i RAID Battery Assembly” on page 145.
- 5 Remove the three screws that secure the RAID battery and lift the RAID battery away from the LSI 9265-8i RAID battery carrier. See Figure 3-21.

Figure 3-21. Removing and Installing the LSI 9265-8i RAID Battery

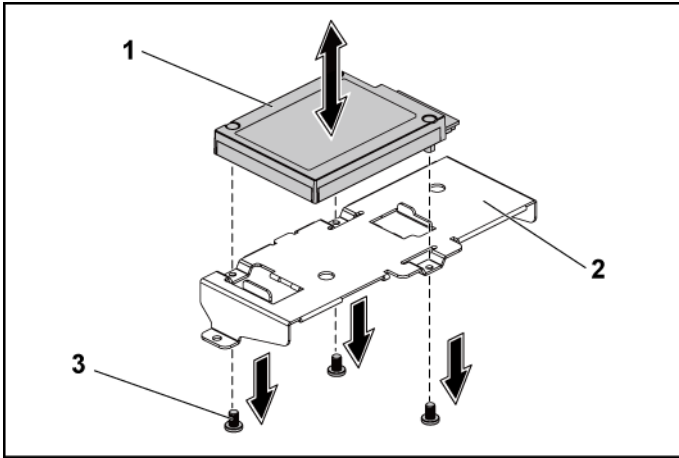

- | | | | |
|---|--------------------------|---|----------------------------------|
| 1 | LSI 9265-8i RAID battery | 2 | LSI 9265-8i RAID battery carrier |
| 3 | screw (3) | | |

Installing the LSI 9265-8i RAID Battery

- 1 Attach the RAID battery onto the RAID battery carrier. See Figure 3-21.
- 2 Replace the screws securing the RAID battery. See Figure 3-21.
- 3 Connect the cable connecting to the LSI 9265-8i card.
- 4 Install the system-board assembly. See “Installing a System-Board Assembly” on page 116.
- 5 Remove the LSI 9265-8i RAID battery assembly from the system-board assembly. See “Installing the LSI 9265-8i RAID Battery Assembly” on page 146.
- 6 Reconnect the system to the electrical outlet and turn the system on, including any attached peripherals.

Expansion-Card Connector

Removing the Expansion-Card Connector



CAUTION: Many repairs may only be done by a certified service technician. You should only perform troubleshooting and simple repairs as authorized in your product documentation, or as directed by the online or telephone service and support team. Damage due to servicing that is not authorized by Dell is not covered by your warranty. Read and follow the safety instructions that came with the product.

- 1 Recommend to turn off the system, including any attached peripherals, and disconnect the system from its electrical outlet.
- 2 Remove the system-board assembly. See "Removing a System-Board Assembly" on page 115.
- 3 Remove the expansion card. See "Removing the Expansion Card" on page 125.
- 4 Remove the two screws securing the expansion-card connector to the expansion-card bracket. See Figure 3-22.
- 5 Pull the expansion-card connector away from the expansion-card bracket. See Figure 3-22.

Figure 3-22. Removing and Installing the Expansion-Card Connector

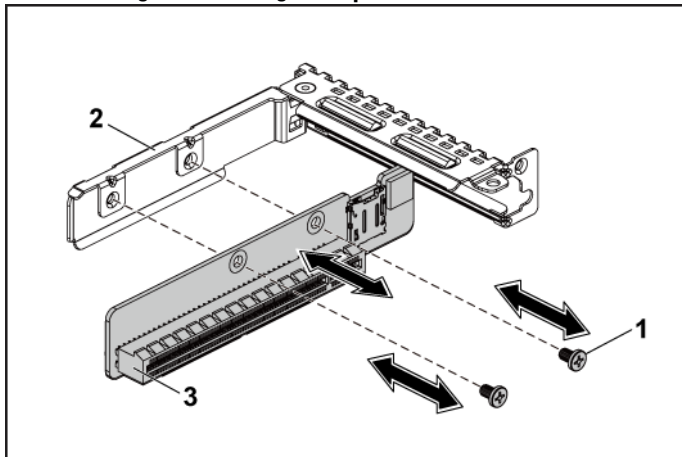

- | | | | |
|---|--------------------------|---|------------------------|
| 1 | screw (2) | 2 | expansion-card bracket |
| 3 | expansion-card connector | | |

Installing the Expansion-Card Connector



CAUTION: Many repairs may only be done by a certified service technician. You should only perform troubleshooting and simple repairs as authorized in your product documentation, or as directed by the online or telephone service and support team. Damage due to servicing that is not authorized by Dell is not covered by your warranty. Read and follow the safety instructions that came with the product.

- 1 Place the expansion-card connector into the expansion-card bracket. See Figure 3-22.
- 2 Replace the two screws securing the expansion-card connector to the expansion-card bracket. See Figure 3-22.
- 3 Install expansion card. See “Installing the Expansion Card” on page 127.
- 4 Install the system-board assembly. See "Installing a System-Board

Assembly" on page 116.

- 5 Reconnect the system to its electrical outlet and turn on the system, including any attached peripherals.

Mezzanine Card

Removing the SAS Mezzanine Card



CAUTION: Many repairs may only be done by a certified service technician. You should only perform troubleshooting and simple repairs as authorized in your product documentation, or as directed by the online or telephone service and support team. Damage due to servicing that is not authorized by Dell is not covered by your warranty. Read and follow the safety instructions that came with the product.

- 1 Recommend to turn off the system, including any attached peripherals, and disconnect the system from its electrical outlet.
- 2 Remove the system-board assembly. See "Removing a System-Board Assembly" on page 115.
- 3 Disconnect all the cables from the SAS mezzanine card.
- 4 Remove the three screws that secure the SAS mezzanine-card assembly to the system-board assembly. See Figure 3-23.
- 5 Remove the SAS mezzanine-card assembly away from the mezzanine-card bridge board on the system-board assembly. See Figure 3-23.

Figure 3-23. Removing and Installing the SAS Mezzanine-Card Assembly

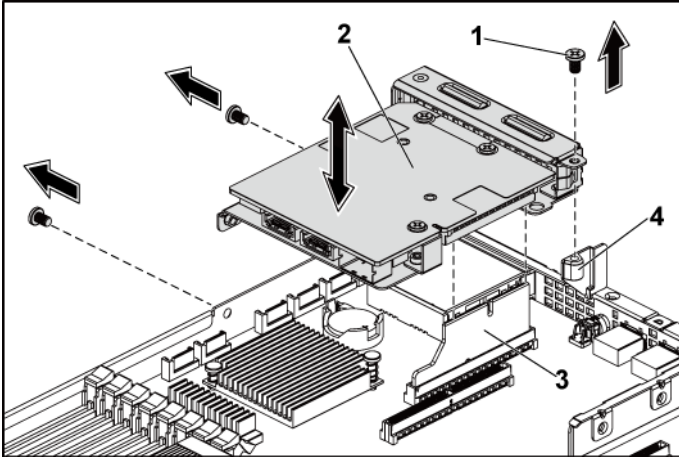

- | | | | |
|---|-----------------------------|---|-----------------------------|
| 1 | screw (3) | 2 | SAS mezzanine-card assembly |
| 3 | mezzanine-card bridge board | 4 | system-board assembly |
- 6 Remove the three screws that secure the SAS mezzanine card to the bracket. See Figure 3-24.
- 7 Remove SAS mezzanine card away from the bracket. See Figure 3-24.

Figure 3-24. Removing and Installing the SAS Mezzanine Card

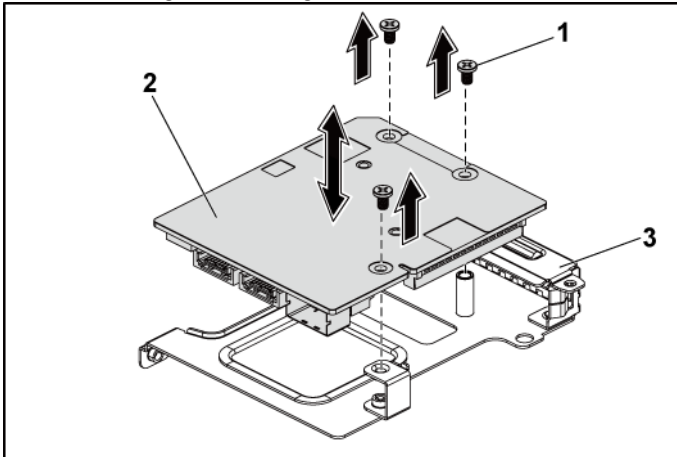

- 1 screw (3)
- 2 SAS mezzanine card
- 3 SAS mezzanine-card bracket

Installing the SAS Mezzanine Card



CAUTION: Many repairs may only be done by a certified service technician. You should only perform troubleshooting and simple repairs as authorized in your product documentation, or as directed by the online or telephone service and support team. Damage due to servicing that is not authorized by Dell is not covered by your warranty. Read and follow the safety instructions that came with the product.

- 1 Align the SAS mezzanine card to the bracket by the three screw holes. See Figure 3-24.
- 2 Replace the three screws to that secure the SAS mezzanine card to the bracket. See Figure 3-24.
- 3 Install the SAS mezzanine-card assembly to the mezzanine-card bridge board on the system-board assembly. See Figure 3-23.
- 4 Replace the three screws that secure the SAS mezzanine-card assembly to the system-board assembly. See Figure 3-23.

- 5 Reconnect all the cables to the SAS mezzanine card.
- 6 Install the system-board assembly. See "Installing a System-Board Assembly" on page 116.
- 7 Reconnect the system to its electrical outlet and turn on the system, including any attached peripherals.

Cable Routing for SAS Mezzanine Card

- 1 Reconnect all the cables to the SAS mezzanine card. Make sure the cables should go through the cable clip ring. See Figure 3-25.

Figure 3-25. Cable Routing for SAS Mezzanine Card

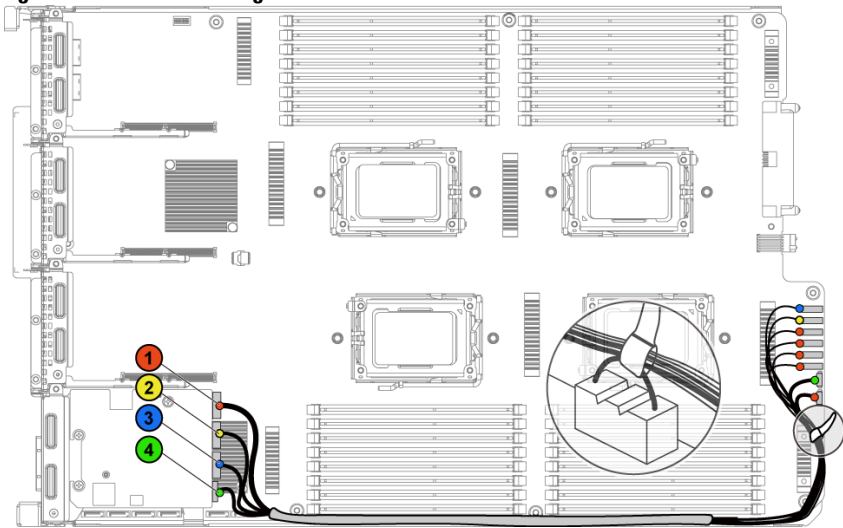

Item	Cable	From (SAS Mezzanine Card)	To (HDD to Backplane SATAII Connectors)
①	SAS/SGPIO cable	SAS_ports 0~3	SATAII connectors 1~4 and SGPIO A
②	SAS cable	SAS_port 4	SATAII connector 5
③	SAS cable	SAS_port 5	SATAII connector 6
④	SGPIO cable	SGPIO B	SGPIO B

Removing the 10GbE Mezzanine Card



CAUTION: Many repairs may only be done by a certified service technician. You should only perform troubleshooting and simple repairs as authorized in your product documentation, or as directed by the online or telephone service and support team. Damage due to servicing that is not authorized by Dell is not covered by your warranty. Read and follow the safety instructions that came with the product.

- 1 Recommend to turn off the system, including any attached peripherals, and disconnect the system from its electrical outlet.
- 2 Remove the system-board assembly. See "Removing a System-Board Assembly" on page 115.
- 3 Disconnect all the cables from the 10GbE mezzanine card.
- 4 Remove the three screws that secure the 10GbE mezzanine-card assembly. See Figure 3-26.
- 5 Lift the 10GbE mezzanine-card assembly away from the mezzanine-card bridge board on the system board. See Figure 3-26.

Figure 3-26. Removing and Installing the 10GbE Mezzanine-Card Assembly

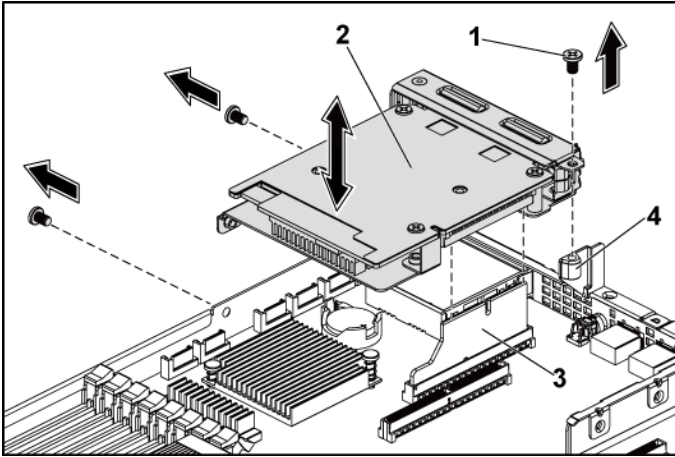

- | | | | |
|---|-----------------------------|---|-------------------------------|
| 1 | screw (3) | 2 | 10GbE mezzanine-card assembly |
| 3 | mezzanine-card bridge board | 4 | system-board assembly |
- 6 Remove the three screws that secure the 10GbE mezzanine card to the bracket. See Figure 3-27.
- 7 Remove the 10GbE mezzanine card from the bracket. See Figure 3-27.

Figure 3-27. Removing and Installing the 10GbE Mezzanine Card

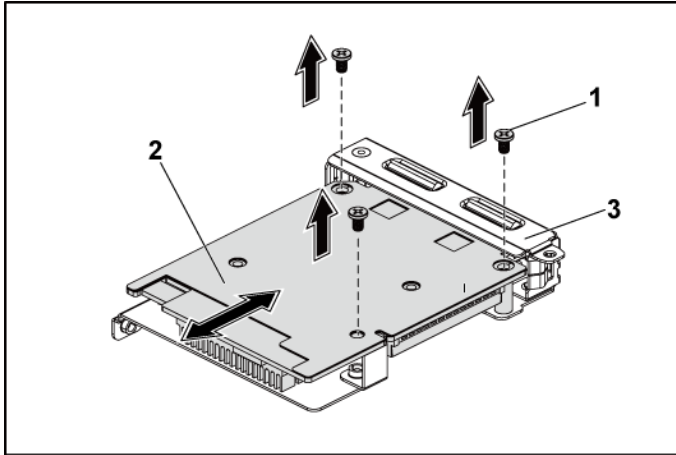

- 1 screw (3)
- 2 10GbE mezzanine card
- 3 10GbE mezzanine-card bracket

Installing the 10GbE Mezzanine Card



CAUTION: Many repairs may only be done by a certified service technician. You should only perform troubleshooting and simple repairs as authorized in your product documentation, or as directed by the online or telephone service and support team. Damage due to servicing that is not authorized by Dell is not covered by your warranty. Read and follow the safety instructions that came with the product.

- 1 Put the two ports of the 10GbE mezzanine card through the two slots of the bracket. See Figure 3-27.
- 2 Install the three screws to secure the 10GbE mezzanine card to the bracket. See Figure 3-27.
- 3 Install the 10GbE mezzanine-card assembly to the mezzanine-card bridge board on the system-board assembly. See Figure 3-26.
- 4 Install the three screws to secure the 10GbE mezzanine-card assembly

to the system-board assembly. See Figure 3-26.

- 5 Reconnect all the cables to the 10GbE mezzanine card.
- 6 Install the system-board assembly. See "Installing a System-Board Assembly" on page 116.
- 7 Reconnect the system to its electrical outlet and turn on the system, including any attached peripherals.

Removing the Mellanox Card



CAUTION: Many repairs may only be done by a certified service technician. You should only perform troubleshooting and simple repairs as authorized in your product documentation, or as directed by the online or telephone service and support team. Damage due to servicing that is not authorized by Dell is not covered by your warranty. Read and follow the safety instructions that came with the product.

- 1 Recommend to turn off the system, including any attached peripherals, and disconnect the system from its electrical outlet.
- 2 Remove the system-board assembly. See "Removing a System-Board Assembly" on page 115.
- 3 Disconnect all the cables from the Mellanox card.
- 4 Remove the three screws that secure the Mellanox card assembly. See Figure 3-28.
- 5 Lift the Mellanox card assembly away from the mezzanine-card bridge board on the system board. See Figure 3-28.

Figure 3-28. Removing and Installing the Mellanox Card Assembly

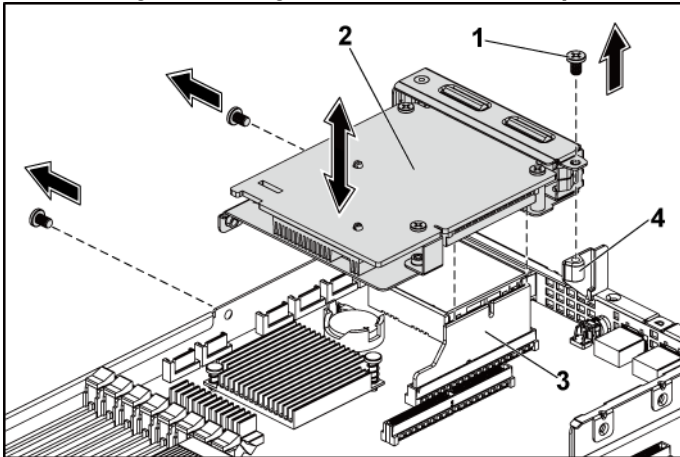

- | | | | |
|---|-----------------------------|---|------------------------|
| 1 | screw (3) | 2 | Mellanox card assembly |
| 3 | mezzanine-card bridge board | 4 | system-board assembly |

- 6 Remove the three screws that secure the Mellanox card to the bracket. See Figure 3-29.
- 7 Remove the Mellanox card from the bracket. See Figure 3-29.

Figure 3-29. Removing and Installing the Mellanox Card

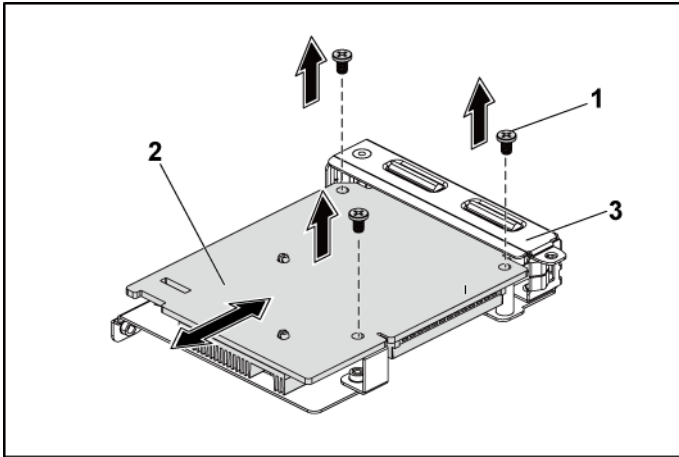

- 1 screw (3)
- 2 Mellanox card
- 3 mezzanine-card bracket

Installing the Mellanox Card



CAUTION: Many repairs may only be done by a certified service technician. You should only perform troubleshooting and simple repairs as authorized in your product documentation, or as directed by the online or telephone service and support team. Damage due to servicing that is not authorized by Dell is not covered by your warranty. Read and follow the safety instructions that came with the product.

- 1 Put the two ports of the Mellanox card through the two slots of the bracket. See Figure 3-29.
- 2 Install the three screws to secure the Mellanox card to the bracket. See Figure 3-29.
- 3 Install the Mellanox card assembly to the mezzanine-card bridge board on the system-board assembly. See Figure 3-28.
- 4 Install the three screws to secure the Mellanox card assembly to the

system-board assembly. See Figure 3-28.

- 5 Reconnect all the cables to the Mellanox card.
- 6 Install the system-board assembly. See "Installing a System-Board Assembly" on page 116.

Reconnect the system to its electrical outlet and turn on the system, including any attached peripherals.

Mezzanine-Card Bridge Board

Removing the Mezzanine-Card Bridge Board



CAUTION: Many repairs may only be done by a certified service technician. You should only perform troubleshooting and simple repairs as authorized in your product documentation, or as directed by the online or telephone service and support team. Damage due to servicing that is not authorized by Dell is not covered by your warranty. Read and follow the safety instructions that came with the product.

- 1 Recommend to turn off the system, including any attached peripherals, and disconnect the system from its electrical outlet.
- 2 Remove the system-board assembly. See "Removing a System-Board Assembly" on page 115.
- 3 Remove the mezzanine card. See "Removing the SAS Mezzanine Card" on page 151 and "Removing the 10GbE Mezzanine Card" on page 154.
- 4 Pull the mezzanine-card bridge board away from the mezzanine slot on the system board. See Figure 3-30.

Figure 3-30. Removing and Installing the Mezzanine-Card Bridge Board

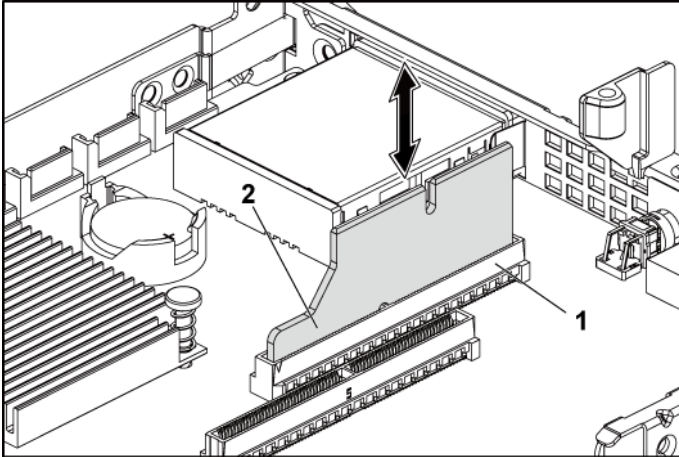

1 mezzanine slot

2 mezzanine-card bridge board

Installing the Mezzanine-Card Bridge Board



CAUTION: Many repairs may only be done by a certified service technician. You should only perform troubleshooting and simple repairs as authorized in your product documentation, or as directed by the online or telephone service and support team. Damage due to servicing that is not authorized by Dell is not covered by your warranty. Read and follow the safety instructions that came with the product.

- 1 Install the mezzanine-card bridge board into the mezzanine slot on the system board. See Figure 3-30.
- 2 Install the mezzanine card. See "Installing the SAS Mezzanine Card" on page 151 and "Installing the 10GbE Mezzanine Card" on page 156.
- 3 Install the system-board assembly. See "Installing a System-Board Assembly" on page 116.
- 4 Reconnect the system to its electrical outlet and turn on the system, including any attached peripherals.

System Memory

Each system board has thirty-two unbuffered or registered DDR3-DIMM slots for the installation of up to thirty-two DDR3-800/1066/1333 memory chips to support the four processors. See "System Board Connectors" on page 229 for the location of the memory modules.

Supported DIMM Configuration

For the sequence of the thirty-two DIMM sockets, see Figure 3-31. When you insert the SR/DR DIMM(s), always start with CHA_DIMM1. See Table 3-7 for possible memory configuration.

Figure 3-31. Memory Slot Locations

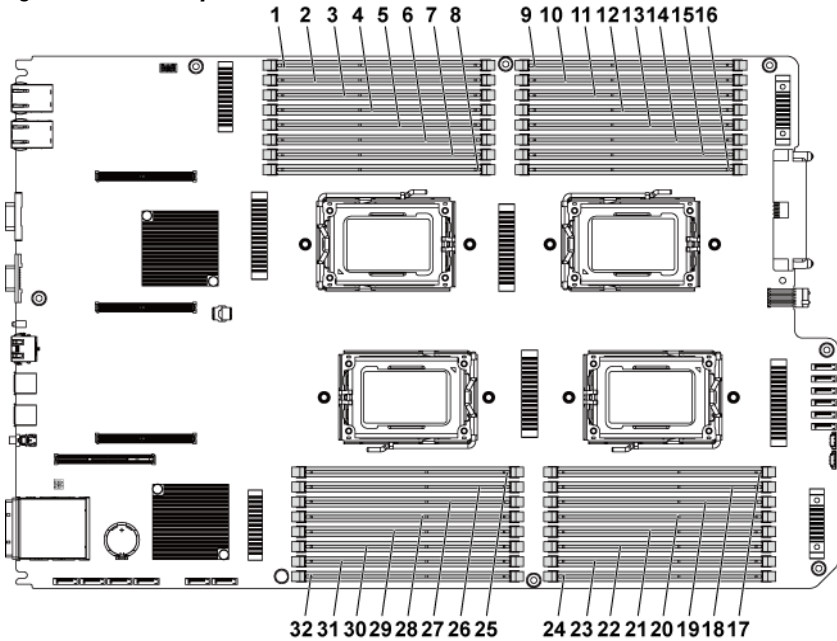

1	DIMM A1_CHA	2	DIMM A2_CHA
3	DIMM A3_CHB	4	DIMM A4_CHB
5	DIMM A5_CHC	6	DIMM A6_CHC
7	DIMM A7_CHD	8	DIMM A8_CHD
9	DIMM C1_CHA	10	DIMM C2_CHA
11	DIMM C3_CHB	12	DIMM C4_CHB
13	DIMM C5_CHC	14	DIMM C6_CHC
15	DIMM C7_CHD	16	DIMM C8_CHD
17	DIMM D8_CHD	18	DIMM D7_CHD
19	DIMM D6_CHC	20	DIMM D5_CHC
21	DIMM D4_CHB	22	DIMM D3_CHB
23	DIMM D2_CHA	24	DIMM D1_CHA
25	DIMM B8_CHD	26	DIMM B7_CHD
27	DIMM B6_CHC	28	DIMM B5_CHC
29	DIMM B4_CHB	30	DIMM B3_CHB
31	DIMM B2_CHA	32	DIMM B1_CHA



NOTE: For the thermal concern, each DIMM socket needs to be installed with a real or dummy DIMM.

Table 3-7. Memory Module Configurations and Limitation (Memory Unit=GB)

		Memory Population																						
# of CPU		2	2	2	4	2	4	2	2	4	2	2	4	2	4	2	4	4	4	4	2	2	4	4
System		32	64	64	64	96	96	128	128	128	160	192	192	256	256	256	320	384	512	256	512	512	1024	
# of DIMMs		8	8	16	16	16	16	8	16	16	8	16	32	16	32	16	16	32	32	32	8	16	16	32
CPU1	A1	4	8	4	4	8	8	16	8	8	16	16	8	16	8	16	16	16	16	16	32	32	32	32
	A2			4	4				8				4	4	8	8	16		4	8	16		32	32
	A3	4	8	4	4	8	8	16	8	8	16	16	8	16	8	16	16	16	16	16	32	32	32	32
	A4			4	4				8				4	4	8	8	16		4	8	16		32	32
	A5	4	8	4	4	8	4	8	8	8	16	16	8	16	8	16	16	16	16	16	32	32	32	32
	A6			4	4				8				4	4	8	8	16		4	8	16		32	32
	A7	4	8	4	4	8	4	8	8	8	16	16	8	16	8	16	16	16	16	16	32	32	32	32
	A8			4	4				8				4	4	8	8	16		4	8	16		32	32
CPU2	B1	4	8	4	4	8	8	16	8	8	16	16	8	16	8	16	16	16	16	16	32	32	32	32
	B2			4	4				8			4	4	8	8	16		4	8	16		32	32	32
	B3	4	8	4	4	8	8	16	8	8	16	16	8	16	8	16	16	16	16	16	32	32	32	32
	B4			4	4				8				4	4	8	8	16		4	8	16		32	32
	B5	4	8	4	4	8	4	8	8	8	16	16	8	16	8	16	16	16	16	16	32	32	32	32
	B6			4	4				8				4	4	8	8	16		4	8	16		32	32
	B7	4	8	4	4	8	4	8	8	8	16	16	8	16	8	16	16	16	16	16	32	32	32	32
	B8			4	4				8				4	4	8	8	16		4	8	16		32	32
CPU3	C1				4		8			8				8		8		16	16	16	16		32	32
	C2												4		8			4	8	16				32
	C3				4		8			8			8		8		16	16	16	16			32	32
	C4												4		8			4	8	16				32
	C5				4		4			8			8		8		16	16	16	16			32	32
	C6												4		8			4	8	16				32
	C7				4		4			8			8		8		16	16	16	16			32	32
	C8												4		8			4	8	16				32
CPU4	D1				4		8			8			8		8		16	16	16	16			32	32
	D2											4		8			4	8	16					32
	D3				4		8			8			8		8		16	16	16	16			32	32
	D4												4		8			4	8	16				32
	D5				4		4			8			8		8		16	16	16	16			32	32
	D6												4		8			4	8	16				32
	D7				4		4			8			8		8		16	16	16	16			32	32
	D8												4		8			4	8	16				32

Removing the Memory Modules



WARNING: The memory modules are hot to the touch for some time after the system has been powered down. Allow time for the memory modules to cool before handling them. Handle the memory modules by the card edges and avoid touching the components on the memory module.



CAUTION: Many repairs may only be done by a certified service technician. You should only perform troubleshooting and simple repairs as authorized in your product documentation, or as directed by the online or telephone service and support team. Damage due to servicing that is not authorized by Dell is not covered by your warranty. Read and follow the safety instructions that came with the product.

- 1 Recommend to turn off the system, including any attached peripherals, and disconnect the system from the electrical outlet.
- 2 Remove the system-board assembly. See "Removing a System-Board Assembly" on page 115.
- 3 Locate the memory module sockets. See Figure 3-31.
- 4 Press down and out on the ejectors on each end of the socket until the memory module pops out of the socket. See Figure 3-32.
- 5 Handle each memory module only on either card edge, making sure not to touch the middle of the memory module.
- 6 Install the system-board assembly. See "Installing a System-Board Assembly" on page 116.
- 7 Reconnect the system to the electrical outlet and turn the system on, including any attached peripherals.

Installing the Memory Modules



WARNING: The memory modules are hot to the touch for some time after the system has been powered down. Allow time for the memory modules to cool before handling them. Handle the memory modules by the card edges and avoid touching the components on the memory module.



CAUTION: Many repairs may only be done by a certified service technician. You should only perform troubleshooting and simple repairs as authorized in your product documentation, or as directed by the online or telephone service and support team. Damage due to servicing that is not authorized by Dell is not covered by your warranty. Read and follow the safety instructions that came with the product.

- 1 Recommend to turn off the system, including any attached peripherals, and disconnect the system from its electrical outlet.
- 2 Remove the system-board assembly. See "Removing a System-Board Assembly" on page 115.
- 3 Locate the memory module sockets. See Figure 3-31.
- 4 Press the ejectors on the memory module socket down and out, as shown in Figure 3-32, to allow the memory module to be inserted into the socket.
- 5 Handle each memory module only on either card edge, making sure not to touch the middle of the memory module.
- 6 Align the memory module's edge connector with the alignment key of the memory module socket, and insert the memory module in the socket. See Figure 3-32.



NOTE: The memory module socket has an alignment key that allows you to install the memory module in the socket in only one way.

Figure 3-32. Installing and Removing a DIMM

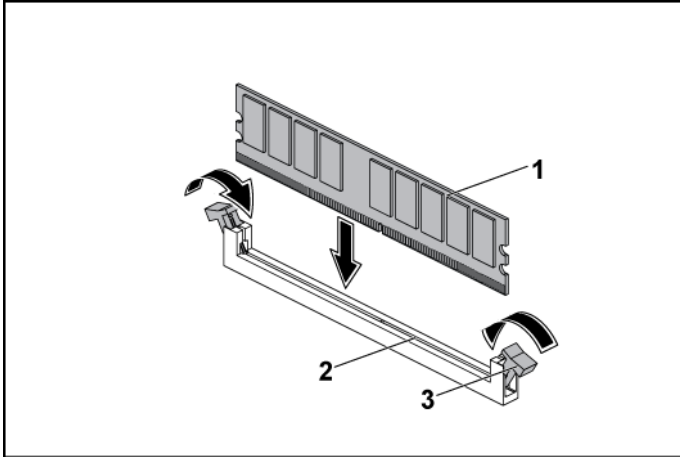

- | | | | |
|---|----------------------------------|---|----------------------|
| 1 | memory module | 2 | memory module socket |
| 3 | memory module socket ejector (2) | | |

- 7 Press down on the memory module with your thumbs to lock the memory module into the socket. See Figure 3-32.
When the memory module is properly seated in the socket, the ejectors on the memory module socket align with the ejectors on the other sockets that have memory modules installed.
- 8 Repeat step 4 through step 7 of this procedure to install the remaining memory modules in the approved configurations. See Table 3-7.
- 9 Install the system-board assembly. See "Installing a System-Board Assembly" on page 116.
- 10 Start up the system. Press <F2> to enter the System Setup program. Check the System Memory settings on the main System Setup screen. The system should have already changed the value to reflect the newly installed memory.
- 11 If the value is incorrect, one or more of the memory modules may not

be installed properly. Repeat step 2 through step 10 of this procedure, to ensure that the memory modules are firmly seated in their sockets.

System Battery

Replacing the System Battery



WARNING: There is a danger of a new battery exploding if it is incorrectly installed. Replace the battery only with the same or equivalent type recommended by the manufacturer. See your safety information for additional information.



CAUTION: Many repairs may only be done by a certified service technician. You should only perform troubleshooting and simple repairs as authorized in your product documentation, or as directed by the online or telephone service and support team. Damage due to servicing that is not authorized by Dell is not covered by your warranty. Read and follow the safety instructions that came with the product.

- 1 Recommend to turn off the system, including any attached peripherals, and disconnect the system from the electrical outlet.
- 2 Remove the system-board assembly. See "Removing a System-Board Assembly" on page 115.
- 3 Locate the battery location. See "System Board Connectors" on page 229.



CAUTION: To avoid damage to the battery connector, you must firmly support the connector while installing or removing a battery.

- 4 Gently pull the retention clip over the battery to the positive side of the connector and lift the battery out of the connector. See Figure 3-33.
- 5 Hold the new battery with the "+" facing the retention clip on the battery connector. See Figure 3-33.
- 6 Gently pull the retention clip towards the positive side of the connector and slide the battery into the connector until the retention

clip snaps into place. See Figure 3-33.

Figure 3-33. Replacing the System Battery

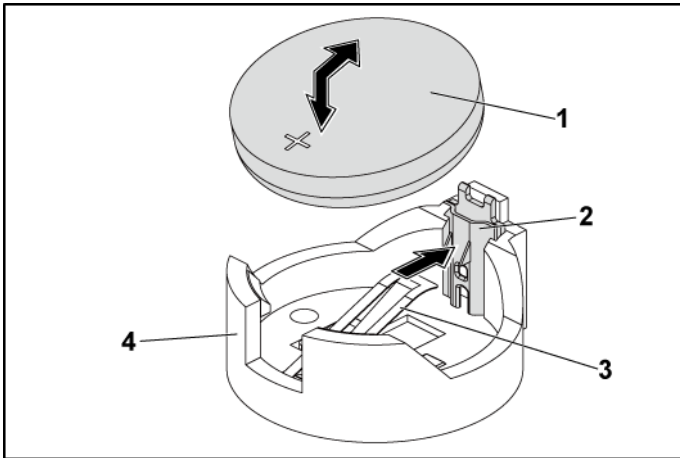

- | | | | |
|---|----------------|---|------------------------------------|
| 1 | system battery | 2 | positive side of battery connector |
| 3 | retention clip | 4 | negative side of battery connector |
- 7 Install the system-board assembly. See “Installing a System-Board Assembly” on page 116.
 - 8 Reconnect the system to the electrical outlet and turn the system on, including any attached peripherals.
 - 9 Enter the System Setup program to confirm that the battery is operating properly. See “Using the System Setup Program” on page 46.
 - 10 Enter the correct time and date in the System Setup program’s **Time** and **Date** fields.
 - 11 Exit the System Setup program.

System Board

Removing a System Board



CAUTION: Many repairs may only be done by a certified service technician. You should only perform troubleshooting and simple repairs as authorized in your product documentation, or as directed by the online or telephone service and support team. Damage due to servicing that is not authorized by Dell is not covered by your warranty. Read and follow the safety instructions that came with the product.

- 1 Recommend to turn off the system and attached peripherals, and disconnect the system from the electrical outlet.
- 2 Remove the system-board assembly. See "Removing a System-Board Assembly" on page 115.
- 3 Remove the air ducts. See "Removing the Air Duct" on page 116.
- 4 Remove the heat sink. See "Removing the Heat Sink" on page 118.
- 5 Remove the expansion-card assembly. See "Removing the Expansion Card" on page 125.
- 6 If installed, remove the SAS mezzanine card or 10GbE mezzanine card. See "Removing the SAS Mezzanine Card" on page 151 or "Removing the 10GbE Mezzanine Card" on page 154.
- 7 Disconnect the hard drive and power cables from the system board.
- 8 Remove the eight screws and then slide the system board. See Figure 3-34.



CAUTION: Do not lift the system board by grasping a memory module, processor, or other components.

- 9 Grasp the system board by the edges and lift the system board away from the system-board assembly. See Figure 3-34.

Figure 3-34. Removing and Installing the System Board

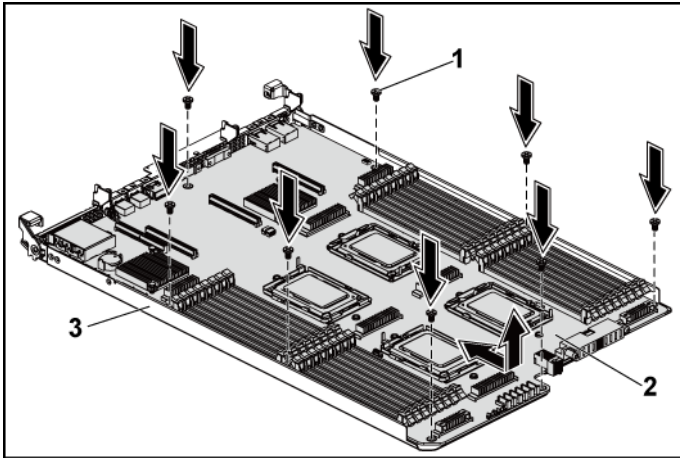

- 1 screw (8)
- 2 system board
- 3 system-board assembly

Installing a System Board

- 1 Unpack the new system board.
- 2 Holding the system board by the edges, slide the system board into the system-board assembly. See Figure 3-34.
- 3 Replace the eight screws to secure the system board to the system-board assembly. See Figure 3-34.
- 4 Transfer the processors to the new system board. See "Removing a Processor" on page 122 and "

- 6 Installing a Processor" on page 124.
- 7 Remove the memory modules and transfer them to the same locations on the new board. See "Removing the Memory Modules" on page 166 and "Installing the Memory Modules" on page 167.
- 8 Replace the air ducts. See "Installing the Air Duct" on page 117.
- 9 Connect the hard drive and power cables to the system board.
- 10 If applicable, install the SAS mezzanine card. See "Installing the SAS Mezzanine Card" on page 153.
- 11 Install the expansion-card assembly. See Figure 3-11 on page 127.
- 12 Install the system-board assembly. See "Installing a System-Board Assembly" on page 116.
- 13 Reconnect the system to its electrical outlet and turn on the system, including any attached peripherals.

Opening and Closing the System



WARNING: Whenever you need to lift the system, get others to assist you. To avoid injury, do not attempt to lift the system by yourself.



CAUTION: This system must be operated with the system cover installed to ensure proper cooling.



CAUTION: Many repairs may only be done by a certified service technician. You should only perform troubleshooting and simple repairs as authorized in your product documentation, or as directed by the online or telephone service and support team. Damage due to servicing that is not authorized by Dell is not covered by your warranty. Read and follow the safety instructions that came with the product.

Opening the System

- 1 Recommend to turn off the system, including any attached peripherals, and disconnect the system from the electrical outlet.
- 2 Remove the securing screw from the system cover. See Figure 3-35.
- 3 Press the cover release latch lock. See Figure 3-35.
- 4 Grasp cover on both the sides with your palm on the traction pad, slide out and lift the cover away from the system. See Figure 3-35.

Figure 3-35. Opening and Closing the System

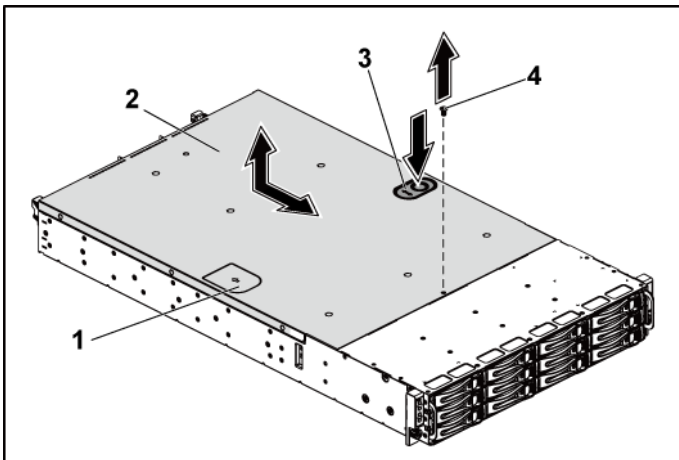

- | | | | |
|---|--------------------------|---|----------------|
| 1 | traction pad | 2 | system cover |
| 3 | cover release latch lock | 4 | securing screw |

Closing the System

- 1 Place the cover on the chassis and slide it to the front of the chassis until it snaps into place. See Figure 3-35.
- 2 Secure the cover with the securing screw. See Figure 3-35.

Cooling Fans

Removing a Cooling Fan



WARNING: Do not attempt to operate the system without the cooling fans.



WARNING: The cooling fan can continue to spin for some time after the system has been powered down. Allow time for the fan to stop spinning before removing it from the system.



CAUTION: Many repairs may only be done by a certified service technician. You should only perform troubleshooting and simple repairs as authorized in your product documentation, or as directed by the online or telephone service and support team. Damage due to servicing that is not authorized by Dell is not covered by your warranty. Read and follow the safety instructions that came with the product.

- 1 Recommend to turn off the system, including any attached peripherals, and disconnect the system from its electrical outlet.
- 2 Open the system. See "Opening the System" on page 174.
- 3 Disconnect the fan's power cable from the fan-controller board.
Note the routing of the cable through the tabs on the chassis as you remove them from the system. You must route these cables properly when you replace them to prevent the cables from being pinched or crimped.
- 4 Lift the fan out of the cooling-fan bracket.

Figure 3-36. Removing and Installing a Cooling Fan

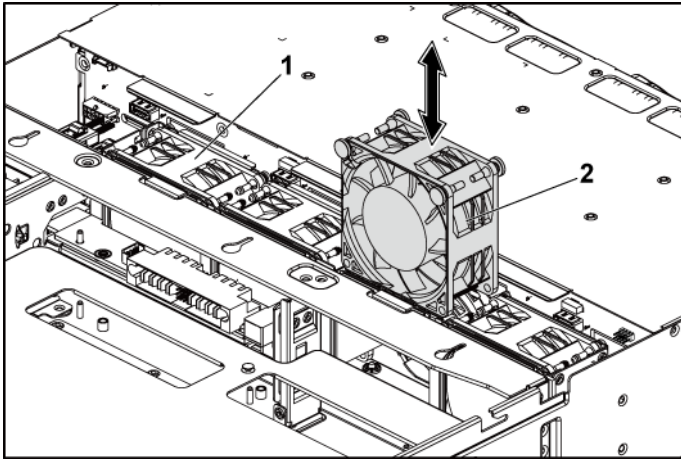

1 cooling-fan bracket

2 cooling fans (4)

Installing a Cooling Fan



CAUTION: Many repairs may only be done by a certified service technician. You should only perform troubleshooting and simple repairs as authorized in your product documentation, or as directed by the online or telephone service and support team. Damage due to servicing that is not authorized by Dell is not covered by your warranty. Read and follow the safety instructions that came with the product.

- 1 Align the cooling fan and slide it in the cooling-fan bracket until the cooling fan is firmly seated. See Figure 3-36.



NOTE: The fan blades should face the front panel of the system.

- 2 Connect the fan's power cable to the connector on the fan-controller board. See Figure 3-48.

You must route these cables properly through the tabs on the chassis to prevent them from being pinched or crimped.

- 3 Close the system. See "Closing the System" on page 174.
- 4 Reconnect the system to its electrical outlet and turn on the system, including any attached peripherals.

Middle Planes

Removing the Middle Planes



CAUTION: Many repairs may only be done by a certified service technician. You should only perform troubleshooting and simple repairs as authorized in your product documentation, or as directed by the online or telephone service and support team. Damage due to servicing that is not authorized by Dell is not covered by your warranty. Read and follow the safety instructions that came with the product.

- 1 Recommend to turn off the system, including any attached peripherals, and disconnect the system from its electrical outlet.
- 2 Open the system. See "Opening the System" on page 174.
- 3 Remove the system-board assemblies. See "Removing a System-Board Assembly" on page 115.
- 4 Remove the cooling fans. See "Removing a Cooling Fan" on page 175.
- 5 Lift the cooling-fan bracket out of the chassis. See Figure 3-37.

Figure 3-37. Removing and Installing the Cooling-Fan Bracket

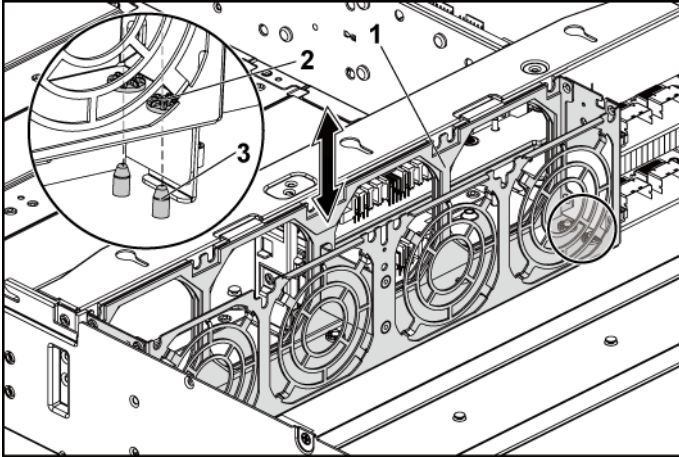

1 cooling-fan bracket

2 locking-tab hole (6)

3 locking tab (6)

- 6 Remove the screws that secure the upper middle plane to the middle plane holder. See Figure 3-38.
- 7 Disconnect all the cables from the upper middle plane.
Note the routing of the cable underneath the tabs on the chassis as you remove them from the system. You must route these cables properly when you replace them to prevent the cables from being pinched or crimped.
- 8 Lift the upper middle plane out. See Figure 3-38.

Figure 3-38. Removing and Installing the Upper Middle Plane

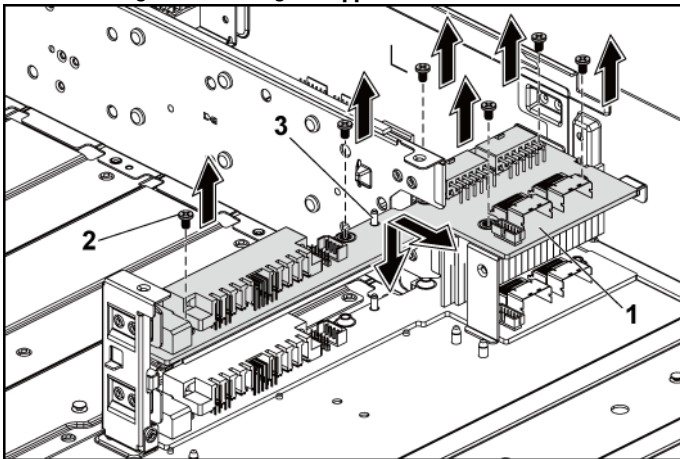

- 1 upper middle plane
- 2 screw (6)
- 3 stand-off on middle plane holder (2)

- 9 Remove the screws that secure the mid-plane holder support to the chassis. See Figure 3-39.
- 10 Lift the mid-plane holder support out of the chassis. See Figure 3-39.

Figure 3-39. Removing and Installing the Mid-plane Holder Support

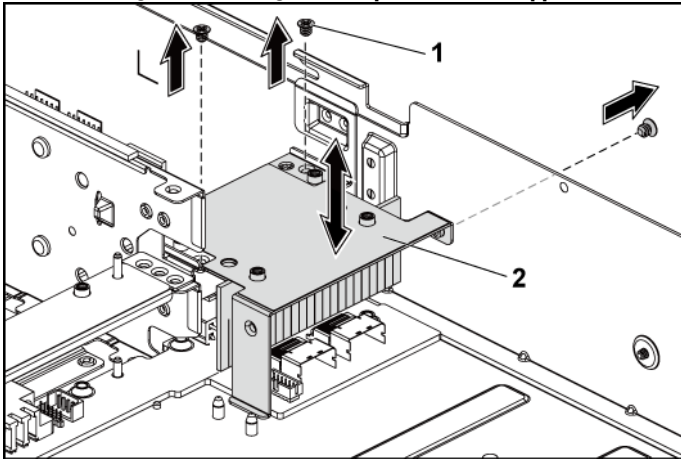

1 screw (3)

2 mid-plane holder support

- 11 Remove the screws that secure the mid-plane holder to the chassis. See Figure 3-40.
- 12 Lift the mid-plane holder out of the chassis. See Figure 3-40.

Figure 3-40. Removing and Installing the Mid-plane Holder

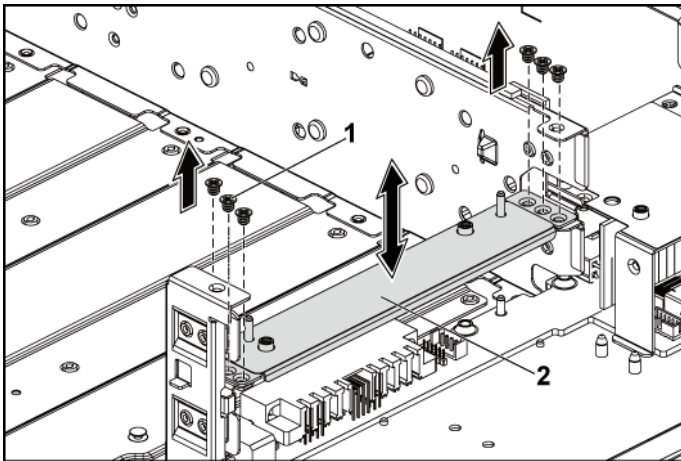

- | | | | |
|---|-----------|---|------------------|
| 1 | screw (6) | 2 | mid-plane holder |
|---|-----------|---|------------------|
- 13 Remove the screws that secure the lower middle plane to the chassis. See Figure 3-41.
 - 14 Disconnect all the cables from the lower middle plane.
Note the routing of the cable underneath the tabs on the chassis as you remove them from the system. You must route these cables properly when you replace them to prevent the cables from being pinched or crimped.
 - 15 Lift the lower middle plane out of the chassis. See Figure 3-41.

Figure 3-41. Removing and Installing the Lower Middle Plane

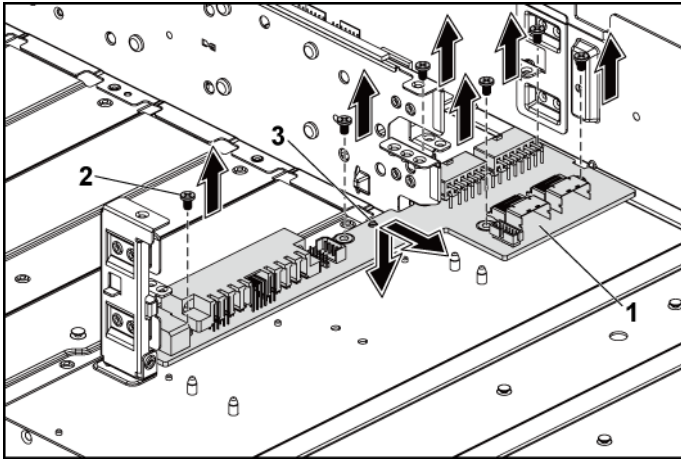

- 1 lower middle plane
- 2 screw (6)
- 3 stand-off on the chassis (2)

Installing the Middle Planes



CAUTION: Many repairs may only be done by a certified service technician. You should only perform troubleshooting and simple repairs as authorized in your product documentation, or as directed by the online or telephone service and support team. Damage due to servicing that is not authorized by Dell is not covered by your warranty. Read and follow the safety instructions that came with the product.

- 1 Place the lower middle plane into the chassis. Make sure that the two stand-offs on the chassis are inserted through the slot on the lower middle plane. See Figure 3-41.
- 2 Replace the screws that secure the lower middle plane to the chassis. See Figure 3-41.
- 3 Connect all the cables to the lower middle plane.

You must route these cables properly through the tabs on the chassis to prevent them from being pinched or crimped.

- 4 Place the upper middle plane holder into the chassis. See Figure 3-40.
- 5 Replace the screws that secure the middle plane holder to the chassis. See Figure 3-40.
- 16 Place the middle plane holder support into the chassis. See Figure 3-39.
- 6 Replace the screws that secure the middle plane holder support to the chassis. See Figure 3-39.
- 7 Place the upper middle plane on the middle plane holder. Make sure that the two stand-offs on the middle plane holder are inserted through the slot on the upper middle plane. See Figure 3-38.
- 8 Replace the screws that secure the upper middle plane to the middle plane holder. See Figure 3-38.
- 9 Connect all the cables to the upper middle plane.
You must route these cables properly through the tabs on the chassis to prevent them from being pinched or crimped.
- 10 Align the locking-tab holes on the cooling-fan bracket to the corresponding locking tabs on the chassis, and then press down the cooling-fan bracket into the chassis until secured firmly. See Figure 3-37.
- 11 Replace the cooling fans. See "Installing a Cooling Fan" on page 176.
- 12 Replace the system-board assemblies. See "Installing a System-Board Assembly" on page 116.
- 13 Close the system, see "Closing the System" on page 174.
- 14 Reconnect the system to its electrical outlet and turn on the system, including any attached peripherals.

Backplanes



NOTE: This section describes the replacement of 3.5" hard-drive backplane, with the 3.5 " hard-drive backplane with CPLD as example. For replacement information about 2.5" hard-drive backplanes, see "Expander Card (Optional)" on page 195.

Removing the 3.5" Hard-Drive Backplane



CAUTION: Many repairs may only be done by a certified service technician. You should only perform troubleshooting and simple repairs as authorized in your product documentation, or as directed by the online or telephone service and support team. Damage due to servicing that is not authorized by Dell is not covered by your warranty. Read and follow the safety instructions that came with the product.

- 1 Recommend to turn off the system, including any attached peripherals, and disconnect the system from its electrical outlet.
- 2 Remove all the hard drives. See "Removing a Hard-Drive Carrier" on page 106.
- 3 Open the system. See "Opening the System" on page 174.



CAUTION: To prevent damage to the drives and backplane, you must remove the hard drives from the system before removing the backplane.



CAUTION: You must note the number of each hard drive and temporarily label them before removal so that you can replace them in the same locations.

- 4 Remove the screws that secure the hard-drive cage to the chassis. See Figure 3-42.

Figure 3-42. Removing and Installing the 3.5" Hard-Drive Cage (1)

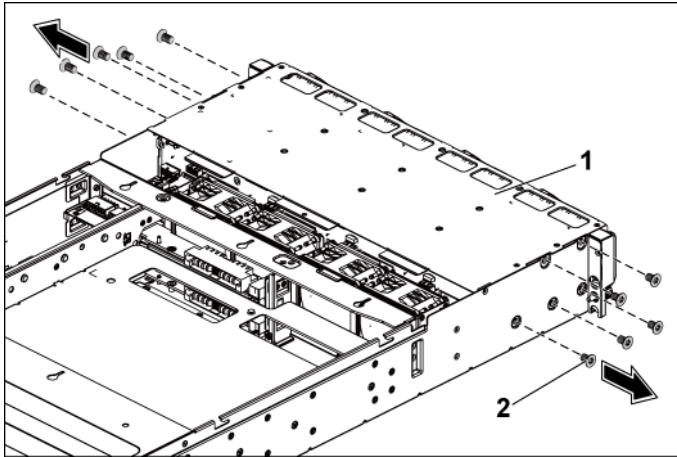

- | | | | |
|---|----------------------|---|------------|
| 1 | 3.5" hard-drive cage | 2 | screw (10) |
|---|----------------------|---|------------|
- 5 Remove the screws that secure the front-panel assemblies to the chassis. See Figure 3-43.
 - 6 Disconnect all the cables from the backplane. See Figure 5-3 for 3.5" hard drives and Figure 5-7 for 2.5" hard drives.
Note the routing of the cable underneath the tabs on the chassis as you remove them from the system. You must route these cables properly when you replace them to prevent the cables from being pinched or crimped.
 - 7 Disconnect front panel cables from the fan controller board. See Figure 3-48.
Note the routing of the cable underneath the tabs on the chassis as you remove them from the system. You must route these cables properly when you replace them to prevent the cables from being pinched or crimped.
 - 8 Remove the hard-drive cage from the chassis. See Figure 3-43.

Figure 3-43. Removing and Installing the 3.5" Hard-Drive Cage (2)

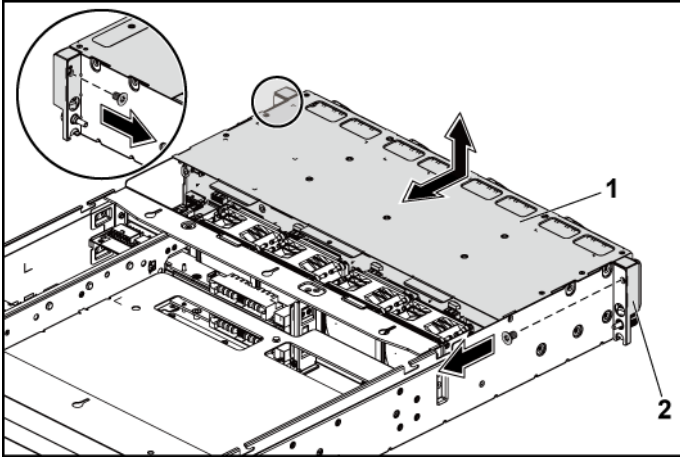

- 1 3.5" hard-drive cage
- 2 front-panel assembly (2)
- 9 Remove the screws that secure the backplane to the hard-drive cage.
- 10 Remove the backplane from the hard-drive cage. See Figure 3-44.

Figure 3-44. Removing and Installing the Backplane From the Hard-Drive Cage

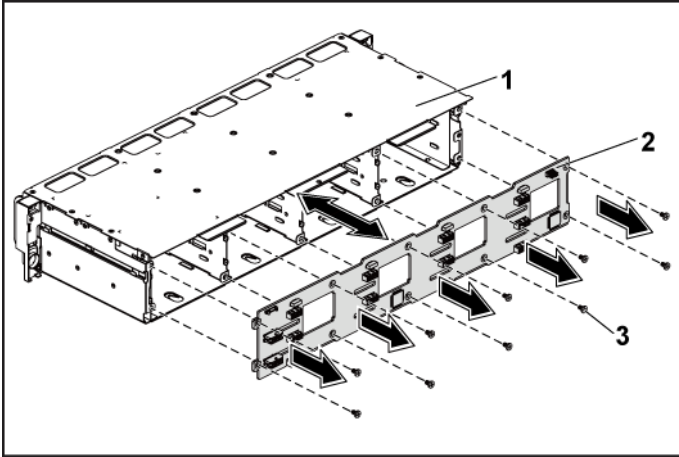

1 3.5" hard-drive cage
3 screw (10)

2 3.5" hard-drive backplane

Installing the 3.5" Hard-Drive Backplane



CAUTION: Many repairs may only be done by a certified service technician. You should only perform troubleshooting and simple repairs as authorized in your product documentation, or as directed by the online or telephone service and support team. Damage due to servicing that is not authorized by Dell is not covered by your warranty. Read and follow the safety instructions that came with the product.

- 1 Install the backplane into the hard-drive cage. See Figure 3-44.
- 2 Replace the screws that secure the backplane to the hard-drive cage. See Figure 3-44.
- 3 Replace the hard-drive cage into the chassis. See Figure 3-43.
- 4 Replace the screws that secure the front-panel assemblies to the chassis. See Figure 3-43.
- 5 Connect all cables to the backplane. See Figure 5-3 for 3.5" hard drives.

- You must route these cables properly through the tabs on the chassis to prevent them from being pinched or crimped.
- 6 Connect front panel cables to the fan controller board. See Figure 3-48. You must route these cables properly through the tabs on the chassis to prevent them from being pinched or crimped.
 - 7 Replace the screws that secure the hard-drive cage. See Figure 3-42.
 - 8 Close the system, see "Closing the System" on page 174.
 - 9 Replace the hard drives. See "Installing a Hard Drive Into a Hard-Drive Carrier" on page 109.
 - 10 Reconnect the system to its electrical outlet and turn on the system, including any attached peripherals.

Power Distribution Boards

Removing a Power Distribution Board



CAUTION: Many repairs may only be done by a certified service technician. You should only perform troubleshooting and simple repairs as authorized in your product documentation, or as directed by the online or telephone service and support team. Damage due to servicing that is not authorized by Dell is not covered by your warranty. Read and follow the safety instructions that came with the product.



NOTE: This system has two power distribution boards. The procedure to remove and install both the power distribution boards is similar. To access the second power distribution board at the bottom, remove the power distribution board at the top.

- 1 Recommend to turn off the system, including any attached peripherals, and disconnect the system from its electrical outlet.
- 2 Open the system. See "Opening the System" on page 174.
- 3 Remove the power supply. See "Removing a Power Supply" on page 110.
- 4 Disconnect all the cables from the first power distribution board. See

Figure 3-46.

- 5 Remove the screws securing the first power distribution board to the system. See Figure 3-45.
- 6 Lift the power distribution board out of the system. See Figure 3-45.



NOTE: To remove the second power distribution board that is below the first power distribution board, remove the power distribution board connector and angle the board before lifting.

Figure 3-45. Removing and Installing a Power Distribution Board

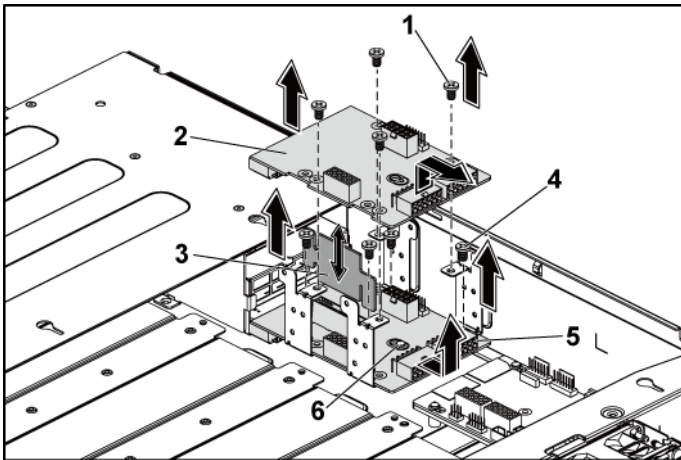

- | | | | |
|---|---------------------------------------|---|------------------------------|
| 1 | screw (4) | 2 | 1st power distribution board |
| 3 | power distribution board bridge board | 4 | screw (4) |
| 5 | 2nd power distribution board | 6 | stand-off on the chassis |

Installing a Power Distribution Board



CAUTION: Many repairs may only be done by a certified service technician. You should only perform troubleshooting and simple repairs as authorized in your product documentation, or as directed by the online or telephone service and support team. Damage due to servicing that is not authorized by Dell is not covered by your warranty. Read and follow the safety instructions that came with the product.



CAUTION: If removed, you must replace the second power distribution board at the bottom and the power distribution board-connector before replacing the first power distribution board at the top.

- 1 If removed, first place the second power distribution board in the system. See Figure 3-45. Otherwise skip to step 5.



NOTE: To install the second power distribution board that is below the first power distribution board, angle the board during installation.

- 2 Replace the screws securing the second power distribution board to the system. See Figure 3-45.
- 3 Replace the power distribution board bridge board. See Figure 3-45.
- 4 Connect all the cables to the second power distribution board. See Figure 3-46.
You must route these cables properly to prevent them from being pinched or crimped.
- 5 Replace the screws securing the first power distribution board to the system. See Figure 3-45.
- 6 Connect all the cables to the first power distribution board. See Figure 3-46
You must route these cables properly through the tabs on the chassis to prevent them from being pinched or crimped.
- 7 Replace the power supply. See "Installing a Power Supply" on page 114.
- 8 Close the system. See "Closing the System" on page 174.

- Reconnect the system to its electrical outlet and turn on the system, including any attached peripherals.

Cable Routing for Power Distribution Board

Figure 3-46. Cable Routing–Power Distribution Board

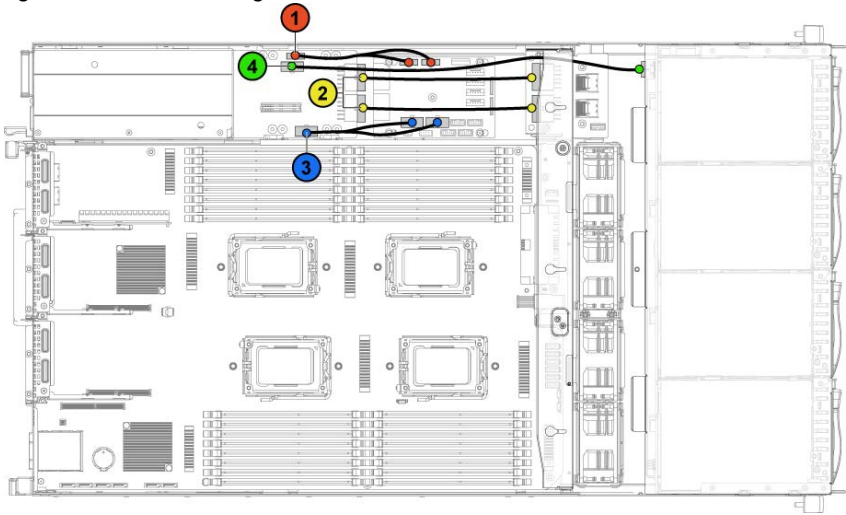

Item	Cable	From (Power Distribution Boards)	To
1	PMBus to power distribution board cables	PMBus connectors (J6)	Fan Control Board
2	Main power cables	Main power connectors (J2, J3)	Middle Plane
3	System fan board power	System fan board power connectors (J7)	Fan Control Board

Item	Cable	From (Power Distribution Boards)	To
	cables		
4	Hard-drive backplane power cables	Hard-drive backplane power connectors (J5)	Backplane

Fan Controller Board

Removing the Fan Controller Board



CAUTION: Many repairs may only be done by a certified service technician. You should only perform troubleshooting and simple repairs as authorized in your product documentation, or as directed by the online or telephone service and support team. Damage due to servicing that is not authorized by Dell is not covered by your warranty. Read and follow the safety instructions that came with the product.

- 1 Recommend to turn off the system, including any attached peripherals, and disconnect the system from its electrical outlet.
- 2 Open the system. See "Opening the System" on page 174.
- 3 Disconnect the cables from the power distribution boards.
- 4 Disconnect the cables from the fan controller board. See Figure 3-48. Note the routing of the cable underneath the tabs on the chassis as you remove them from the system. You must route these cables properly when you replace them to prevent the cables from being pinched or crimped.
- 5 Reconnect the cables from the power distribution boards.
- 6 Remove the screw securing the fan controller board to the chassis. See Figure 3-47.

- 7 Slide and lift the fan controller board out of the chassis. See Figure 3-47.

Figure 3-47. Removing and Installing the Fan Controller Board

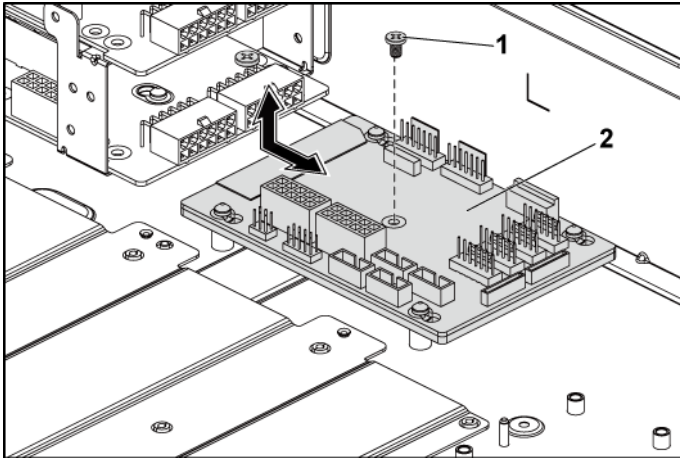

1 screw

2 fan controller board

Installing the Fan Controller Board



CAUTION: Many repairs may only be done by a certified service technician. You should only perform troubleshooting and simple repairs as authorized in your product documentation, or as directed by the online or telephone service and support team. Damage due to servicing that is not authorized by Dell is not covered by your warranty. Read and follow the safety instructions that came with the product.

- 1 Place the fan controller board into the chassis and slide it into place. See Figure 3-47.
- 2 Replace the screw to secure the fan controller board to the chassis. See Figure 3-47.
- 3 Connect all the cables to the fan controller board. See Figure 3-48.

You must route these cables properly through the tabs on the chassis to prevent them from being pinched or crimped.

- 4 Replace the power distribution boards. See "Installing a Power Distribution Board" on page 190.
- 5 Close the system. See "Closing the System" on page 174.
- 6 Reconnect the system to its electrical outlet and turn on the system, including any attached peripherals.

Cable Routing for Fan Control Board

Figure 3-48. Cable Routing–Fan Control Board

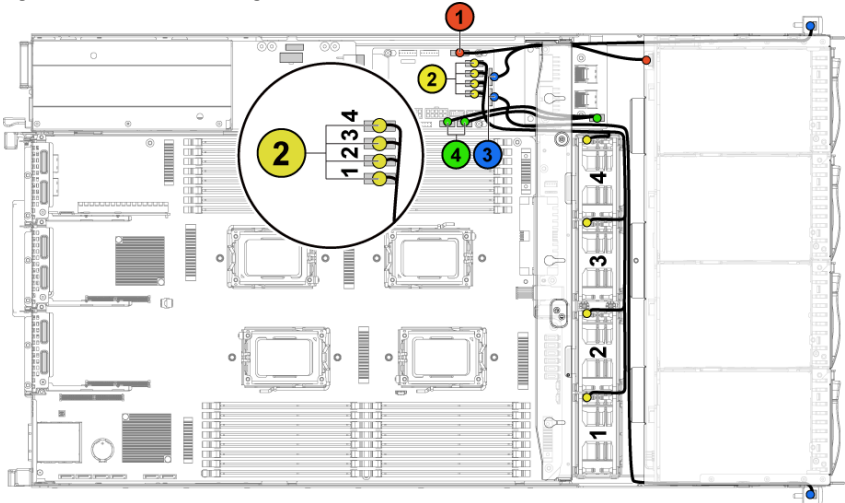

Item	Cable	From (Fan Control Board)	To
①	Hard-drive backplane I ² C cable	Hard-drive backplane connector (J17)	Backplane
②	System fan	System fan connectors	System fans

Item	Cable	From (Fan Control Board)	To
	cables	(J12, J19, J11, J16)	
3	Front panel cables	Front-panel connectors (J31, J32)	Front panels
4	Front panel to motherboard cables	Front-panel connectors for system board (J23, J24)	Middle Planes

Expander Card (Optional)



NOTE: The information in this section uses the 2.5" SATA2 and SAS backplane with expander as example.

Removing the Expander Card



CAUTION: Many repairs may only be done by a certified service technician. You should only perform troubleshooting and simple repairs as authorized in your product documentation, or as directed by the online or telephone service and support team. Damage due to servicing that is not authorized by Dell is not covered by your warranty. Read and follow the safety instructions that came with the product.

- 1 Recommend to turn off the system, including any attached peripherals, and disconnect the system from its electrical outlet.
- 2 Remove all the hard drives. See "Removing a Hard-Drive Carrier" on page 106.
- 3 Open the system. See "Opening the System" on page 174.



CAUTION: To prevent damage to the drives and backplane, you must remove the hard drives from the system before removing the backplane.



CAUTION: You must note the number of each hard drive and temporarily label them before removal so that you can replace them in the same locations.

- 4 Remove the screws that secure the 2.5" hard-drive cage to the chassis.
See Figure 3-49.

Figure 3-49. Removing and Installing the 2.5" Hard-Drive Cage (1)

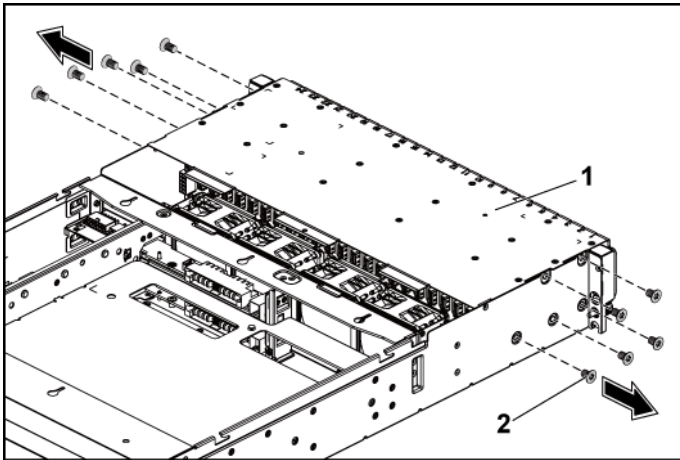

- | | | | |
|---|----------------------|---|------------|
| 1 | 2.5" hard-drive cage | 2 | screw (10) |
|---|----------------------|---|------------|
- 5 Remove the screws that secure the front-panel assemblies to the chassis.
See Figure 3-49.
 - 6 Disconnect all the cables from the backplane. See Figure 5-7 for 2.5" hard drives.
Note the routing of the cable underneath the tabs on the chassis as you remove them from the system. You must route these cables properly when you replace them to prevent the cables from being pinched or crimped.
 - 7 Disconnect all the cables from the expander card.
Note the routing of the cable underneath the tabs on the chassis as you remove them from the system. You must route these cables properly

when you replace them to prevent the cables from being pinched or crimped.

- 8 Disconnect front panel cables from the fan controller board. See Figure 3-48.

Note the routing of the cable underneath the tabs on the chassis as you remove them from the system. You must route these cables properly when you replace them to prevent the cables from being pinched or crimped.

- 9 Remove the hard-drive cage from the chassis. See Figure 3-50.

Figure 3-50. Removing and Installing the Hard-Drive Cage (2)

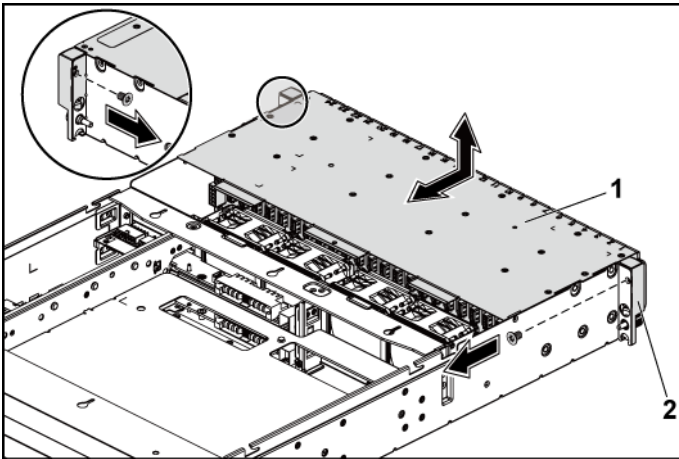

- | | | | |
|---|----------------------|---|--------------------------|
| 1 | 2.5" hard-drive cage | 2 | front-panel assembly (2) |
|---|----------------------|---|--------------------------|

- 10 Remove the screws that secure the backplane to the hard-drive cage. See Figure 3-51.

- 11 Remove the backplane with the expander card from the hard-drive cage. See Figure 3-51.

Figure 3-51. Removing and Installing the Backplane with the Expander Card

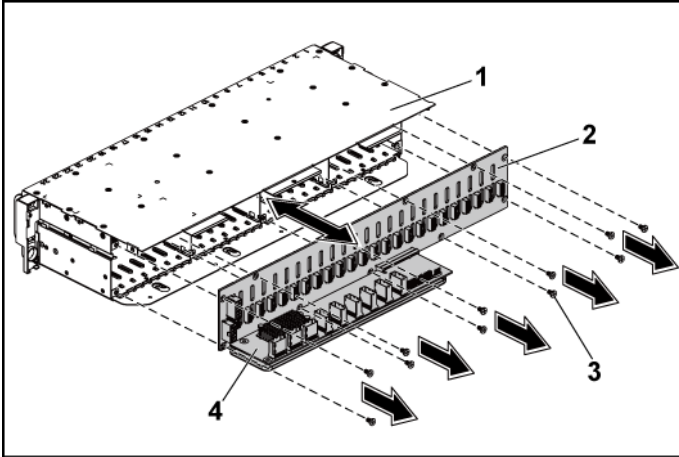

1 2.5" hard-drive cage
3 screw (11)

2 2.5" hard-drive backplane
4 expander card

- 12 Remove the expander card from the 2.5" hard-drive backplane. See Figure 3-52.

Figure 3-52. Removing and Installing the Expander Card From the Backplane

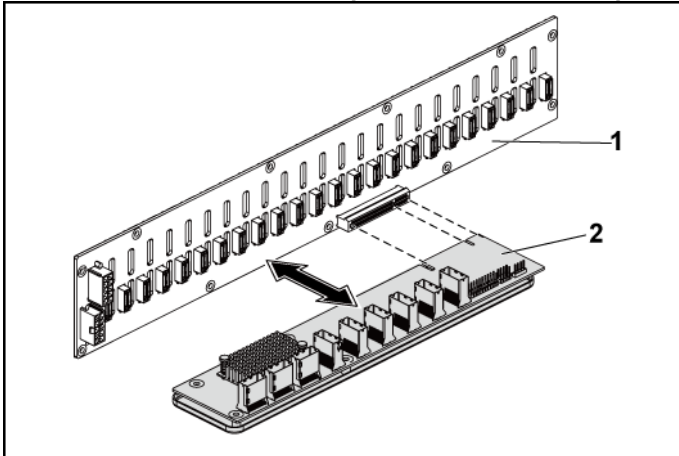

- 1 2.5" hard-drive backplane 2 expander card

Installing the Expander Card



CAUTION: Many repairs may only be done by a certified service technician. You should only perform troubleshooting and simple repairs as authorized in your product documentation, or as directed by the online or telephone service and support team. Damage due to servicing that is not authorized by Dell is not covered by your warranty. Read and follow the safety instructions that came with the product.

- 1 Install the expander card into the 2.5" hard-drive backplane. See Figure 3-52.
- 2 Install the 2.5" hard-drive backplane into the hard-drive cage. See Figure 3-51.
- 3 Replace the screws that secure the backplane to the hard-drive cage.

See Figure 3-51.

- 4 Replace the hard-drive cage into the chassis. See Figure 3-50.
- 5 Replace the screws that secure the front-panel assemblies to the chassis. See Figure 3-50.
Connect all the cables to the backplane. See Figure 5-3 for 2.5" hard drives. You must route these cables properly through the tabs on the chassis to prevent them from being pinched or crimped.
- 6 Connect all the cables to the expander card.
You must route these cables properly through the tabs on the chassis to prevent them from being pinched or crimped.
- 7 Connect front panel cables to the fan controller board. See Figure 3-48.
You must route these cables properly through the tabs on the chassis to prevent them from being pinched or crimped.
- 8 Replace the screws that secure the hard-drive cage. See Figure 3-49.
- 9 Close the system, see "Closing the System" on page 174.
- 10 Replace the hard drives. See "Installing a Hard Drive Into a Hard-Drive Carrier" on page 109.
- 11 Reconnect the system to its electrical outlet and turn on the system, including any attached peripherals.

Front Panels

Removing the Front Panel



CAUTION: Many repairs may only be done by a certified service technician. You should only perform troubleshooting and simple repairs as authorized in your product documentation, or as directed by the online or telephone service and support team. Damage due to servicing that is not authorized by Dell is not covered by your warranty. Read and follow the safety instructions that came with the product.

- 1 Recommend to turn off the system, including any attached peripherals, and disconnect the system from the electrical outlet.
- 2 Remove all the hard drives. See "Removing a Hard-Drive Carrier" on page 106.
- 3 Open the system. See "Opening the System" on page 174.
- 4 Disconnect all the cables from the backplane. See Figure 5-3 for 3.5" hard drives and Figure 5-7 for 2.5" hard drives.
Note the routing of the cable underneath the tabs on the chassis as you remove them from the system. You must route these cables properly when you replace them to prevent the cables from being pinched or crimped.
- 5 Disconnect front panel cables from the fan controller board. See Figure 3-48.
Note the routing of the cable underneath the tabs on the chassis as you remove them from the system. You must route these cables properly when you replace them to prevent the cables from being pinched or crimped.
- 6 Remove the screws that secure the hard-drive cage to the chassis. See Figure 3-42.
- 7 Remove the screws that secure the front-panel assembly to the chassis. See Figure 3-43.
- 8 Remove the hard-drive cage from the chassis. See Figure 3-43.
- 9 Remove the screws that secure the front-panel assembly to the hard-drive cage. See Figure 3-53.
- 10 Remove the front-panel assembly from the hard-drive cage. See Figure 3-53.

Figure 3-53. Removing and Installing a Front-Panel Assembly

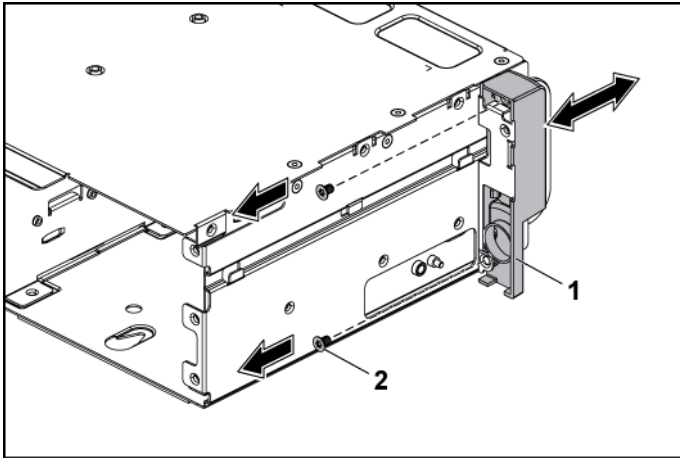

1 front-panel assembly

2 screw (2)

11 Push aside the retention hooks on the front-panel assembly. See Figure 3-54.

12 Remove the front panel from the front-panel assembly. See Figure 3-54.

Figure 3-54. Removing and Installing a Front Panel

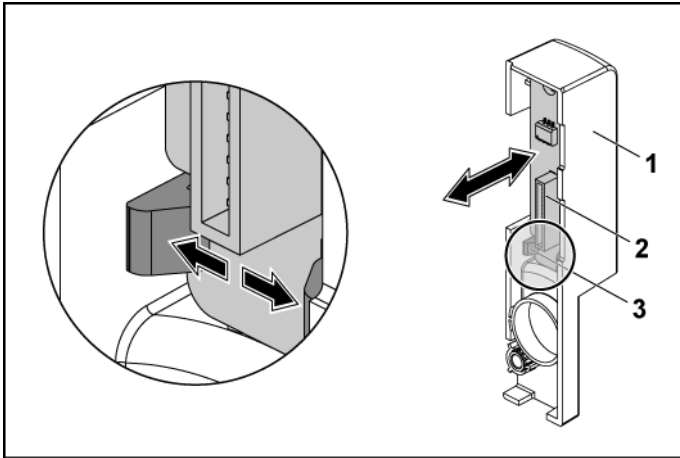

- 1 front-panel assembly
- 3 retention hooks

- 2 front panel

Installing the Front Panel



CAUTION: Many repairs may only be done by a certified service technician. You should only perform troubleshooting and simple repairs as authorized in your product documentation, or as directed by the online or telephone service and support team. Damage due to servicing that is not authorized by Dell is not covered by your warranty. Read and follow the safety instructions that came with the product.

- 1 Push aside the retention hooks on the front-panel assembly and place the front panel into the front-panel assembly. See Figure 3-54.
- 2 Replace the front-panel assembly into the hard-drive cage. See Figure 3-53.
- 3 Replace the screws that secure the front-panel assembly to the hard-drive cage. See Figure 3-53.

- 4 Replace the hard-drive cage into the chassis. See Figure 3-43.
- 5 Replace the screws that secure the front-panel assembly to the chassis. See Figure 3-43.
- 6 Replace the screws that secure the hard-drive cage to the chassis. See Figure 3-42.
- 7 Connect front panel cables to the fan controller board. See Figure 3-48. You must route these cables properly through the tabs on the chassis to prevent them from being pinched or crimped.
- 8 Connect all the cables to the backplane. See Figure 5-3 for 3.5" hard drives and Figure 5-7 for 2.5" hard drives. You must route these cables properly through the tabs on the chassis to prevent them from being pinched or crimped.
- 9 Close the system. See "Closing the System" on page 174.
- 10 Replace the hard drives. See "Installing a Hard Drive Into a Hard-Drive Carrier" on page 109.
- 11 Reconnect the system to its electrical outlet and turn on the system, including any attached peripherals.

Sensor Boards

Removing the Sensor Board for 3.5" Hard Drive System



CAUTION: Many repairs may only be done by a certified service technician. You should only perform troubleshooting and simple repairs as authorized in your product documentation, or as directed by the online or telephone service and support team. Damage due to servicing that is not authorized by Dell is not covered by your warranty. Read and follow the safety instructions that came with the product.

- 1 Recommend to turn off the system, including any attached peripherals, and disconnect the system from the electrical outlet.

- 2 Remove all the hard drives. See "Removing a Hard-Drive Carrier" on page 106.
- 3 Open the system. See "Opening the System" on page 174.
- 4 Disconnect all the cables from the backplane. See Figure 5-3 for 3.5" hard drives.

Note the routing of the cable underneath the tabs on the chassis as you remove them from the system. You must route these cables properly when you replace them to prevent the cables from being pinched or crimped.

- 5 Disconnect front panel cables from the fan controller board. See Figure 3-48.

Note the routing of the cable underneath the tabs on the chassis as you remove them from the system. You must route these cables properly when you replace them to prevent the cables from being pinched or crimped.

- 6 Remove the hard drive cage from the chassis. See Figure 3-43.
- 7 Disconnect the cable from the sensor board.
- 8 Remove the screw that secures the sensor board to the hard-drive cage. See Figure 3-55.
- 9 Remove the sensor board from the hard-drive cage. See Figure 3-55.

Figure 3-55. Removing and Installing the Sensor Board

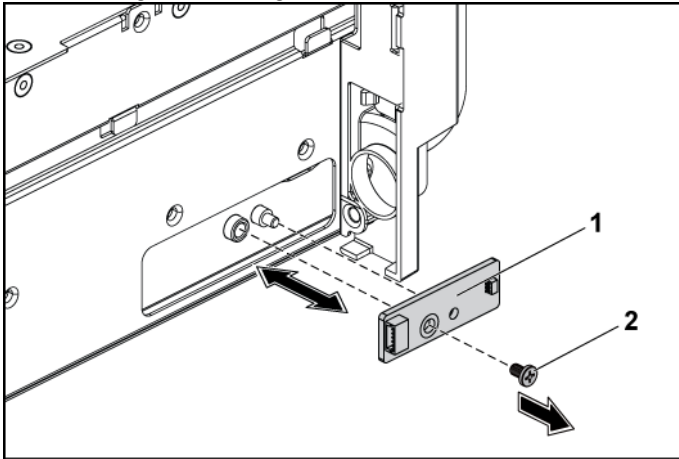

1 sensor board

2 screw

Installing the Sensor Board for 3.5" Hard Drive System



CAUTION: Many repairs may only be done by a certified service technician. You should only perform troubleshooting and simple repairs as authorized in your product documentation, or as directed by the online or telephone service and support team. Damage due to servicing that is not authorized by Dell is not covered by your warranty. Read and follow the safety instructions that came with the product.

- 1 Replace the sensor board into the hard-drive cage. See Figure 3-55.
- 2 Replace the screw that secures the sensor board to the hard-drive cage. See Figure 3-55.
- 3 Connect the sensor board cable to the sensor board.
- 4 Replace the hard-drive cage into the chassis. See Figure 3-43.
- 5 Replace the screws that secure the hard-drive cage to the chassis. See Figure 3-43.
- 6 Connect all the cables to the backplane. See Figure 5-3 for 3.5" hard

drives.

You must route these cables properly through the tabs on the chassis to prevent them from being pinched or crimped.

- 7 Connect front panel cables to the fan controller board. See Figure 3-48. You must route these cables properly through the tabs on the chassis to prevent them from being pinched or crimped.
- 8 Close the system. See "Closing the System" on page 174.
- 9 Replace the hard drives. See "Installing a Hard Drive Into a Hard-Drive Carrier" on page 109.
- 10 Reconnect the system to its electrical outlet and turn on the system, including any attached peripherals.

Removing the Sensor Board for 2.5" Hard Drive System



CAUTION: Many repairs may only be done by a certified service technician. You should only perform troubleshooting and simple repairs as authorized in your product documentation, or as directed by the online or telephone service and support team. Damage due to servicing that is not authorized by Dell is not covered by your warranty. Read and follow the safety instructions that came with the product.

- 1 Recommend to turn off the system, including any attached peripherals, and disconnect the system from the electrical outlet.
- 2 Remove all the hard drives. See "Removing a Hard-Drive Carrier" on page 106.
- 3 Open the system. See "Opening the System" on page 174.
- 4 Disconnect all the cables from the backplane. See Figure 5-7 for 2.5" hard drives.

Note the routing of the cable underneath the tabs on the chassis as you remove them from the system. You must route these cables properly when you replace them to prevent the cables from being pinched or crimped.

- 5 Disconnect front panel cables from the fan controller board. See Figure 3-48.

Note the routing of the cable underneath the tabs on the chassis as you remove them from the system. You must route these cables properly when you replace them to prevent the cables from being pinched or crimped.

- 6 Remove the hard-drive cage from the chassis. See Figure 3-43.
- 7 Disconnect the cable from the sensor-board assembly.
- 8 Remove the screws that secure the sensor-board assembly to the hard-drive cage. See Figure 3-56.
- 9 Remove the sensor-board assembly from the hard-drive cage. See

Figure 3-56.

Figure 3-56. Removing and Installing the Sensor-Board Assembly

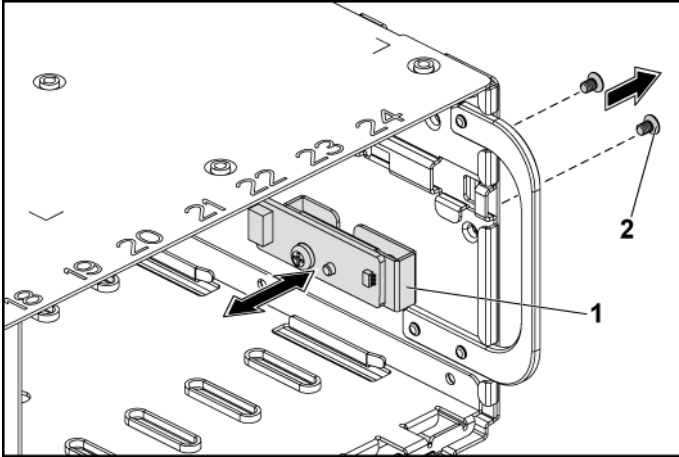

1 sensor-board assembly

2 screw (2)

10 Remove the screw that secures the sensor board to the sensor-board holder. See Figure 3-57.

11 Remove the sensor board from sensor-board holder. See Figure 3-57.

Figure 3-57. Removing and Installing the Sensor Board

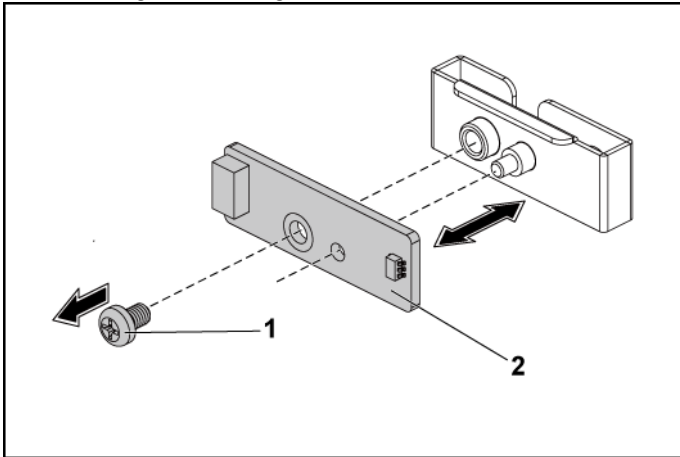

1 screw

2 sensor board

Installing the Sensor Board for 2.5" Hard Drive System



CAUTION: Many repairs may only be done by a certified service technician. You should only perform troubleshooting and simple repairs as authorized in your product documentation, or as directed by the online or telephone service and support team. Damage due to servicing that is not authorized by Dell is not covered by your warranty. Read and follow the safety instructions that came with the product.

- 1 Replace the sensor board into the sensor-board holder. Make sure that the stand-off on the sensor-board holder is inserted into the slot on the sensor board. See Figure 3-57.
- 2 Replace the sensor-board assembly into the hard-drive cage. See Figure 3-56.
- 3 Replace the screw that secures the sensor board to the hard-drive cage. See Figure 3-56.

- 4 Connect the sensor board cable to the sensor board.
- 5 Replace the hard-drive cage into the chassis. See Figure 3-43.
- 6 Replace the screws that secure the hard-drive cage to the chassis. See Figure 3-42.
- 7 Connect all the cables to the backplane. See Figure 5-7 for 2.5" hard drives.
You must route these cables properly through the tabs on the chassis to prevent them from being pinched or crimped.
- 8 Connect front panel cables to the fan controller board. See Figure 3-48.
You must route these cables properly through the tabs on the chassis to prevent them from being pinched or crimped.
- 9 Close the system. See "Closing the System" on page 174.
- 10 Replace the hard drives. See "Installing a Hard Drive Into a Hard-Drive Carrier" on page 109.
- 11 Reconnect the system to its electrical outlet and turn on the system, including any attached peripherals.

Troubleshooting Your System

Safety First – For You and Your System



WARNING: Whenever you need to lift the system, get others to assist you. To avoid injury, do not attempt to lift the system by yourself.



WARNING: Before removing the system cover, disconnect all power, then unplug the AC power cord, and then disconnect all peripherals, and all LAN lines.



CAUTION: Many repairs may only be done by a certified service technician. You should only perform troubleshooting and simple repairs as authorized in your product documentation, or as directed by the online or telephone service and support team. Damage due to servicing that is not authorized by Dell is not covered by your warranty. Read and follow the safety instructions that came with the product.

Installation Problems

Perform the following checks when you troubleshoot installation problems:

- Check all cable and power connections (including all rack cable connections).
- Unplug the power cord and wait for one minute. Then reconnect the power cord and try again.
- If the network is reporting an error, verify that the system has enough memory and disk space.
- Remove all added peripherals, one at a time, and try to turn on the system. If after removing a peripheral the system works, it may be a problem with the peripheral or a configuration problem between the peripheral and the system. Contact the peripheral vendor for assistance.
- If the system does not power on, check the LED display. If the power LED is not on, you may not be receiving AC power. Check the AC power cord to make sure that it is securely connected.

Troubleshooting System Startup Failure

If your system halts during startup, especially after installing an operating system or reconfiguring your system's hardware, check for invalid memory configurations. These could cause the system to halt at startup without any video output. See "System Memory" on page 154.

For all other startup issues, note any system messages that appear onscreen, see "Using the System Setup Program" on page 46 for more information.

Troubleshooting External Connections

Ensure that all external cables are securely attached to the external connectors on your system before troubleshooting any external devices. See Figure 1-1, Figure 1-6, and Figure 1-9 for the front- and back-panel connectors on your system.

Troubleshooting the Video Subsystem

- 1 Check the system and power connections to the monitor.
- 2 Check the video interface cabling from the system to the monitor.

Troubleshooting a USB Device

Use the following steps to troubleshoot a USB keyboard and/or mouse. For other USB devices, go to step 5.

- 1 Disconnect the keyboard and mouse cables from the system briefly and reconnect them.
- 2 Connect the keyboard/mouse to the USB port(s) on the opposite side of the system.
- 3 If the problem is resolved, restart the system, enter the System Setup

- program, and check if the nonfunctioning USB ports are enabled.
- 4 Replace the keyboard/mouse with another working keyboard/mouse.
If the problem is resolved, replace the faulty keyboard/mouse.
If the problem is not resolved, proceed to the next step to begin troubleshooting the other USB devices attached to the system.
 - 5 Power down all attached USB devices, and disconnect them from the system.
 - 6 Restart the system and, if your keyboard is functioning, enter the system setup program. Verify that all USB ports are enabled. See "USB Configuration" on page 64.
If your keyboard is not functioning, you can also use remote access. If the system is not accessible, see "Switch and Jumper Settings" on page 242 for instructions on setting the NVRAM_CLR jumper inside your system and restoring the BIOS to the default settings.
 - 7 Reconnect and power on each USB device one at a time.
 - 8 If a device causes the same problem, power down the device, replace the USB cable, and power up the device.
If the problem persists, replace the device.
If all troubleshooting fails, see "Getting Help" on page 246.

Troubleshooting a Serial I/O Device

- 1 Turn off the system and any peripheral devices connected to the serial port.
- 2 Swap the serial interface cable with another working cable, and turn on the system and the serial device.
If the problem is resolved, replace the interface cable.
- 3 Turn off the system and the serial device, and swap the device with a comparable device.

- 4 Turn on the system and the serial device.
If the problem is resolved, replace the serial device.
If the problem persists, see "Getting Help" on page 246.

Troubleshooting a NIC

- 1 Restart the system and check for any system messages pertaining to the NIC controller.
- 2 Check the appropriate indicator on the NIC connector. See "NIC Indicators (BMC Management Port)" on page 21.
 - If the link indicator does not light, check all cable connections.
 - If the activity indicator does not light, the network driver files might be damaged or missing.
Remove and reinstall the drivers if applicable. See the NIC's documentation.
 - Change the auto-negotiation setting, if possible.
 - Use another connector on the switch or hub.If you are using a NIC card instead of an integrated NIC, see the documentation for the NIC card.
- 3 Ensure that the appropriate drivers are installed and the protocols are bound. See the NIC's documentation.
- 4 Enter the System Setup program and confirm that the NIC ports are enabled. See "Using the System Setup Program" on page 46.
- 5 Ensure that the NICs, hubs, and switches on the network are all set to the same data transmission speed. See the documentation for each network device.
- 6 Ensure that all network cables are of the proper type and do not exceed the maximum length.
If all troubleshooting fails, see "Getting Help" on page 246.

Troubleshooting a Wet System



CAUTION: Many repairs may only be done by a certified service technician. You should only perform troubleshooting and simple repairs as authorized in your product documentation, or as directed by the online or telephone service and support team. Damage due to servicing that is not authorized by Dell is not covered by your warranty. Read and follow the safety instructions that came with the product.

- 1 Turn off the system and attached peripherals, and disconnect the system from the electrical outlet.
- 2 Open the system. See "Opening the System" on page 174.
- 3 Disassemble components from the system. See "Installing System Components" on page 103.
 - Hard drives
 - SAS backplane
 - Expansion-card
 - Power supplies
 - Fans
 - Air ducts
 - Processors and heat sinks
 - Memory modules
- 4 Let the system dry thoroughly for at least 24 hours.
- 5 Reinstall the components you removed in step 3.
- 6 Close the system. See "Closing the System" on page 174.
- 7 Reconnect the system to the electrical outlet, and turn on the system and attached peripherals.

If the system does not start properly, see "Getting Help" on page 246.
- 8 If the system starts properly, shut down the system and reinstall the expansion card that you removed. See "Installing the Expansion Card" on page 127.
- 9 If the system fails to start, see "Getting Help" on page 246.

Troubleshooting a Damaged System



CAUTION: Many repairs may only be done by a certified service technician. You should only perform troubleshooting and simple repairs as authorized in your product documentation, or as directed by the online or telephone service and support team. Damage due to servicing that is not authorized by Dell is not covered by your warranty. Read and follow the safety instructions that came with the product.

- 1 Turn off the system and attached peripherals, and disconnect the system from the electrical outlet.
- 2 Open the system. See "Opening the System" on page 174.
- 3 Ensure that the following components are properly installed:
 - Expansion-card assembly
 - Power supplies
 - Fans
 - Processors and heat sinks
 - Air ducts
 - Memory modules
 - Hard-drive carriers
- 4 Ensure that all cables are properly connected.
- 5 Close the system. See "Closing the System" on page 174.
- 6 If the system fails to start, see "Getting Help" on page 246.

Troubleshooting the System Battery



NOTE: If the system is turned off for long periods of time (for weeks or months), the NVRAM may lose its system configuration information. This situation is caused by a defective battery.

- 1 Re-enter the time and date through the System Setup program. See "System Setup Options at Boot" on page 46.
- 2 Turn off the system and disconnect it from the electrical outlet for

at least one hour.

- 3 Reconnect the system to the electrical outlet and turn on the system.
- 4 Enter the System Setup program.

If the date and time are not correct in the System Setup program, replace the battery. See “Replacing the System Battery” on page 169.



CAUTION: Many repairs may only be done by a certified service technician. You should only perform troubleshooting and simple repairs as authorized in your product documentation, or as directed by the online or telephone service and support team. Damage due to servicing that is not authorized by Dell is not covered by your warranty. Read and follow the safety instructions that came with the product.

If the problem is not resolved by replacing the battery, see “Getting Help” on page 246.



NOTE: Some software may cause the system time to speed up or slow down. If the system seems to operate normally except for the time kept in the System Setup program, the problem may be caused by software rather than by a defective battery.

Troubleshooting Power Supplies

- 1 Identify the faulty power supply by the power supply's fault indicator. See "Power and System Board Indicator Codes" on page 22.



CAUTION: At least one power supply must be installed for the system to operate. Operating the system with only one power supply installed for extended periods of time can cause the system to overheat.

- 2 Reseat the power supply by removing and reinstalling it. See "Power Supplies" on page 110.



NOTE: After installing a power supply, allow several seconds for the system to recognize the power supply and to determine if it is working properly. The power indicator turns green to signify that the power supply is functioning properly.

If the problem persists, replace the faulty power supply.

- 3 If all troubleshooting fails, see "Getting Help" on page 246.

Troubleshooting System Cooling Problems



CAUTION: Many repairs may only be done by a certified service technician. You should only perform troubleshooting and simple repairs as authorized in your product documentation, or as directed by the online or telephone service and support team. Damage due to servicing that is not authorized by Dell is not covered by your warranty. Read and follow the safety instructions that came with the product.

Ensure that none of the following conditions exist:

- System cover, air duct, drive blank, power supply blank, or front or back filler panel is removed.
- Ambient temperature is too high.
- External airflow is obstructed.
- Cables inside the system obstruct airflow.
- An individual cooling fan is removed or has failed. See "Troubleshooting a Fan" on page 220.

Troubleshooting a Fan



CAUTION: Many repairs may only be done by a certified service technician. You should only perform troubleshooting and simple repairs as authorized in your product documentation, or as directed by the online or telephone service and support team. Damage due to servicing that is not authorized by Dell is not covered by your warranty. Read and follow the safety instructions that came with the product.

- 1 Locate the faulty fan indicated by the diagnostic software.
- 2 Turn off the system and all attached peripherals.
- 3 Open the system. See "Opening the System" on page 174.
- 4 Reseat the fan's power cable.
- 5 Restart the system.

If the fan functions properly, close the system. See "Closing the System" on page 174.

- 6 If the fan does not function, turn off the system and install a new fan. See "Cooling Fans" on page 175.
- 7 Restart the system.
If the problem is resolved, close the system. See "Closing the System" on page 174.
If the replacement fan does not operate, see "Getting Help" on page 246.

Troubleshooting System Memory

- 1 If the system is not operational, turn off the system and attached peripherals, and unplug the system from the power source. Wait at least 10 seconds and then reconnect the system to power.
- 2 Turn on the system and attached peripherals and note the messages on the screen.

Go to step 11 if an error message appears indicating a fault with a specific memory module.

- 3 Enter the System Setup program and check the system memory settings. See "System Memory" on page 51. Make any changes to the memory settings, if needed.
If the memory settings match the installed memory but a problem is still indicated, go to step 11.
- 4 Turn off the system and attached peripherals, and disconnect the system from the electrical outlet.
- 5 Remove the system-board assembly. See "Removing a System-Board Assembly" on page 115.
- 6 Check the memory channels and ensure that they are populated correctly. See "Supported DIMM Configuration" on page 163.
- 7 Reseat the memory modules in their sockets. See "Installing the Memory Modules" on page 167.
- 8 Install the system-board assembly. See "Installing a System-Board Assembly" on page 116.
- 9 Reconnect the system to its electrical outlet, and turn on the system and attached peripherals.
- 10 Enter the System Setup program and check the system memory settings. See "System Memory" on page 51.
If the problem is not resolved, proceed with the next step.
- 11 Recommend to turn off the system and attached peripherals, and disconnect the system from the power source.
- 12 Remove the system-board assembly. See "Removing a System-Board Assembly" on page 115.
- 13 If a diagnostic test or error message indicates a specific memory module as faulty, swap or replace the module.
- 14 To troubleshoot an unspecified faulty memory module, replace the

- memory module in the first DIMM socket with a module of the same type and capacity. See "Installing the Memory Modules" on page 167.
- 15 Install the system-board assembly. See "Removing a System-Board Assembly" on page 115.
 - 16 Reconnect the system to its electrical outlet, and turn on the system and attached peripherals.
 - 17 As the system boots, observe any error message that appears and the diagnostic indicators on the front of the system.
 - 18 If the memory problem is still indicated, repeat step 11 through step 17 for each memory module installed.
- If the problem persists after all memory modules have been checked, see "Getting Help" on page 246.

Troubleshooting a Hard Drive



CAUTION: Many repairs may only be done by a certified service technician. You should only perform troubleshooting and simple repairs as authorized in your product documentation, or as directed by the online or telephone service and support team. Damage due to servicing that is not authorized by Dell is not covered by your warranty. Read and follow the safety instructions that came with the product.



CAUTION: This troubleshooting procedure can destroy data stored on the hard drive. Before you proceed, back up all files on the hard drive.

- 1 If your system has a RAID controller and your hard drives are configured in a RAID array, perform the following steps:
 - a. Restart the system and enter the host adapter configuration utility program by pressing <Ctrl><H> for a RAID controller or <Ctrl><C> for a SAS controller.
See the documentation supplied with the host adapter for information about the configuration utility.

- b. Ensure that the hard drive(s) have been configured correctly for the RAID array.
 - c. Take the hard drive offline and reseal the drive. See "Removing a Hard Drive From a Hard-Drive Carrier" on page 108.
 - d. Exit the configuration utility and allow the system to boot to the operating system.
2. Ensure that the required device drivers for your controller card are installed and are configured correctly. See the operating system documentation for more information.
3. Restart the system, enter the System Setup program, and verify that the controller is enabled and the drives appear in the System Setup program.
See "Using the System Setup Program" on page 46.
If the problem persists, see "Getting Help" on page 246.

Troubleshooting a Storage Controller



NOTE: When troubleshooting a SAS RAID controller, also see the documentation for your operating system and the controller.

1. Enter the System Setup program and ensure that the SAS controller is enabled. See "Using the System Setup Program" on page 46.
2. Restart the system and press the applicable key sequence to enter the configuration utility program.
 - <Ctrl><C> for a SAS controller
 - <Ctrl><H> for a RAID controllerSee the controller's documentation for information about configuration settings.
3. Check the configuration settings, make any necessary corrections, and restart the system.



CAUTION: Many repairs may only be done by a certified service technician. You should only perform troubleshooting and simple repairs as authorized in your product documentation, or as directed by the online or telephone service and support team. Damage due to servicing that is not authorized by Dell is not covered by your warranty. Read and follow the safety instructions that came with the product.

- 4 Turn off the system and attached peripherals, and disconnect the system from its electrical outlet.
- 5 Remove the system-board assembly. See "Removing a System-Board Assembly" on page 115.
- 6 Ensure that the controller card is firmly seated into the system board connector. See "Installing the Expansion Card" on page 127.
- 7 If you have a battery-cached SAS RAID controller, ensure that the RAID battery is properly connected and, if applicable, the memory module on the RAID card is properly seated.
- 8 Ensure that the cables are firmly connected to the storage controller and the SAS backplane board.

- 9 Install the system-board assembly. See "Installing a System-Board Assembly" on page 116.
- 10 Reconnect the system to its electrical outlet, and turn on the system and attached peripherals.
If the problem persists, see "Getting Help" on page 246.

Troubleshooting Expansion Cards



NOTE: When troubleshooting an expansion card, see the documentation for your operating system and the expansion card.



CAUTION: Many repairs may only be done by a certified service technician. You should only perform troubleshooting and simple repairs as authorized in your product documentation, or as directed by the online or telephone service and support team. Damage due to servicing that is not authorized by Dell is not covered by your warranty. Read and follow the safety instructions that came with the product.

- 1 Turn off the system and attached peripherals, and disconnect the system from the electrical outlet.
- 2 Remove the system-board assembly. See "Removing a System-Board Assembly" on page 115.
- 3 Ensure that each expansion card is firmly seated in its connector. See "Installing the Expansion Card" on page 127.
- 4 Install the system-board assembly. See "Installing a System-Board Assembly" on page 116.
- 5 Reconnect the system to the electrical outlet, and turn on the system and attached peripherals.
- 6 If the problem is not resolved, see "Getting Help" on page 246.

Troubleshooting Processors



CAUTION: Many repairs may only be done by a certified service technician. You should only perform troubleshooting and simple repairs as authorized in your product documentation, or as directed by the online or telephone service and support team. Damage due to servicing that is not authorized by Dell is not covered by your warranty. Read and follow the safety instructions that came with the product.

- 1 Turn off the system and attached peripherals, and disconnect the system from the electrical outlet.
- 2 Remove the system-board assembly. See "Removing a System-Board Assembly" on page 115.
- 3 Ensure that each processor and heat sink is properly installed. See "

- 5 Installing a Processor" on page 124.
- 6 Install the system-board assembly. See "Installing a System-Board Assembly" on page 116.
- 7 Reconnect the system to the electrical outlet, and turn on the system and attached peripherals.
- 8 If the problem persists, turn off the system and attached peripherals, and disconnect the system from the electrical outlet.
- 9 Remove the system-board assembly. See "Removing a System-Board Assembly" on page 115.
- 10 Remove the other processor(s) and leave only processor 1 in the processor socket 1. See "Removing a Processor" on page 122.
- 11 Install the system-board assembly. See "Installing a System-Board Assembly" on page 116.
- 12 Reconnect the system to the electrical outlet, and turn on the system and attached peripherals.
- 13 If the problem persists, remove processor 1 and install another removed processor in the processor socket 1. See "Removing a Processor" on page 122 and "

- 15 Installing a Processor" on page 124.
- 16 Repeat step 9 and step 10.
If the problem persists, repeat step 11 and 12 with other removed processors (if present) one by one.
- 17 If the problem stops by one of the tested processors, the processor(s) tested before is (are) faulty. See "Getting Help" on page 246.
- 18 If you have tested all the processors and the problem persists, the system board is faulty. See "Getting Help" on page 246.

IRQ Assignment Conflicts

Most PCI devices can share an IRQ with another device, but they cannot use an IRQ simultaneously. To avoid this type of conflict, see the documentation for each PCI device for specific IRQ requirements.

Table 4-1. Assignment Specific IRQ Requirements

IRQ Line	Assignment	IRQ Line	Assignment
IRQ0	8254 timer	IRQ8	RTC
IRQ1	Keyboard controller	IRQ9	SCI
IRQ2	Cascade for IRQ9	IRQ10	USB controller, NIC
IRQ3	Serial port	IRQ11	VGA, USB controller
IRQ4	Serial port	IRQ12	Mouse controller
IRQ5	Free	IRQ13	Processor
IRQ6	Free	IRQ14	Primary IDE controller
IRQ7	USB controller	IRQ15	Secondary IDE controller

Jumpers and Connectors

System Board Connectors

This section provides specific information about the system jumpers. It also provides some basic information on jumpers and switches and describes the connectors on the various boards in the system.

Figure 5-1. System Board Connectors

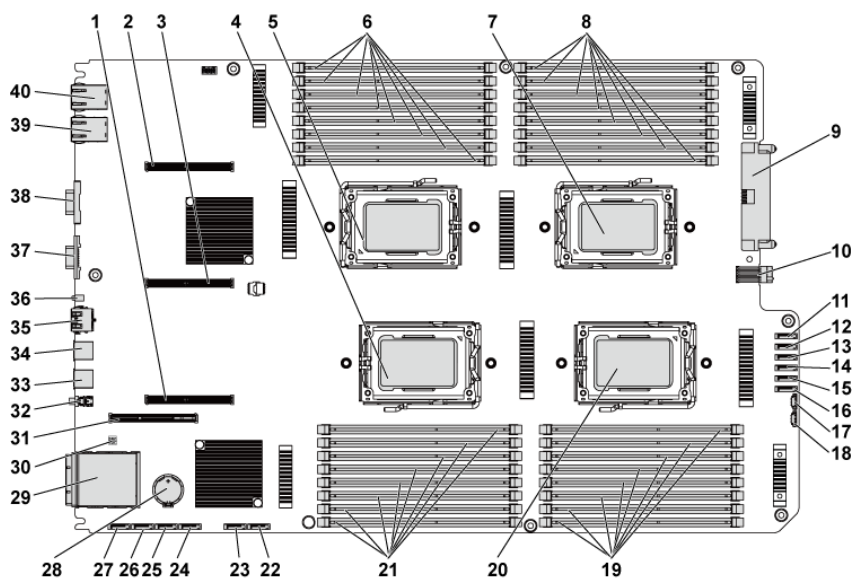

1	PCI-E x16 slot 3	2	PCI-E x16 slot 1
3	PCI-E x16 slot 2	4	processor 2
5	processor 1	6	DIMM sockets for processor 1
7	processor 3	8	DIMM sockets for processor 3
9	main power connector	10	signal board to board connector
11	hard drive to backplane SATAII connector 5	12	hard drive to backplane SATAII connector 4
13	hard drive to backplane SATAII connector 3	14	hard drive to backplane SATAII connector 2
15	hard drive to backplane SATAII connector 1	16	hard drive to backplane SATAII connector 0
17	SGPIO connector 2	18	SGPIO connector 1
19	DIMM sockets for processor 4	20	processor 4
21	DIMM sockets for processor 2	22	onboard SATAII connector 5
23	onboard SATAII connector 4	24	onboard SATAII connector 3
25	onboard SATAII connector 2	26	onboard SATAII connector 1
27	onboard SATAII connector 0	28	system battery
29	IPASS connector	30	system configuration jumper
31	PCI-E x16 mezzanine card slot	32	power button
33	USB port 1	34	USB port 0
35	BMC management port	36	ID LED
37	VGA port	38	serial port
39	NIC 2	40	NIC 1

Backplane Connectors

3.5" Hard-Drive Backplane With CPLD

Figure 5-2. Front View of the Backplane

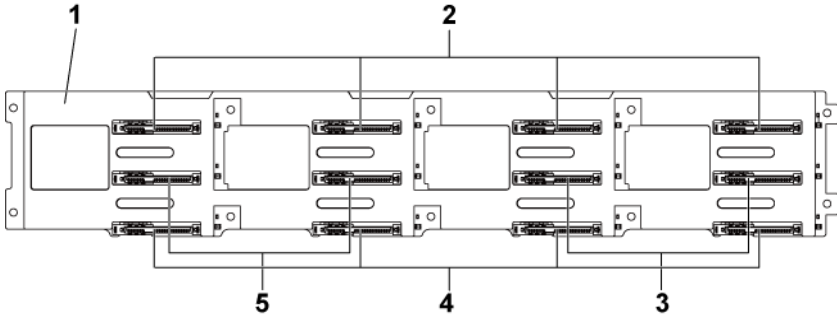

- | | |
|---|---|
| <p>1 3.5" backplane with CPLD</p> <p>3 SATAII and SAS connectors 6-5 (from left to right) for system board 2</p> <p>5 SATAII and SAS connectors 5-6 (from left to right) for system board 1</p> | <p>2 SATAII and SAS connectors 1-4 (from left to right) for system board 1</p> <p>4 SATAII and SAS connectors 1-4 (from left to right) for system board 2</p> |
|---|---|

Figure 5-3. Back View of the Backplane

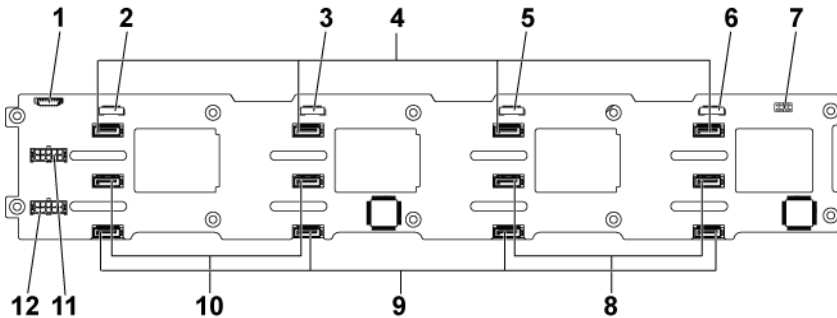

- | | |
|--|--|
| <p>1 fan controller board connector</p> <p>3 SGPIO connector 3</p> | <p>2 SGPIO connector 4</p> <p>4 SATAII hard-drive connectors 1-4 for system board 1 (from right to left)</p> |
|--|--|

- | | | | |
|----|--|----|--|
| 5 | SGPIO connector 2 | 6 | SGPIO connector 1 |
| 7 | backplane jumper | 8 | SATAII hard-drive connectors 5-6 (from right to left) for system board 1 |
| 9 | SATAII hard-drive connectors 1-4 (from right to left) for system board 2 | 10 | SATAII hard-drive connectors 6-5 for system board 2 (from right to left) |
| 11 | backplane power connector for power supply 1 | 12 | backplane power connector for power supply 2 |

3.5" Hard-Drive Backplane With Expander

Figure 5-4. Front View of the Backplane

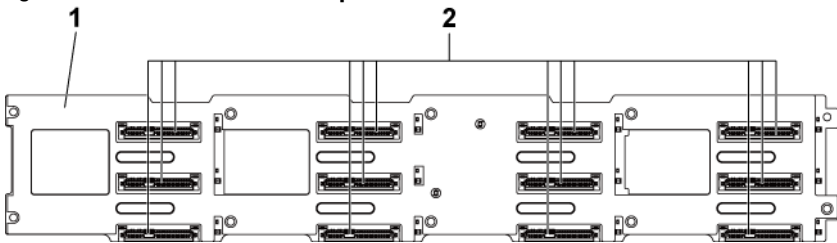

- | | | | |
|---|------------------------------|---|--|
| 1 | 3.5" backplane with expander | 2 | SATAII and SAS connectors 1-4, 5-8, and 9-12 (from left to right, and from up to down) |
|---|------------------------------|---|--|

Figure 5-5. Back View of the Backplane

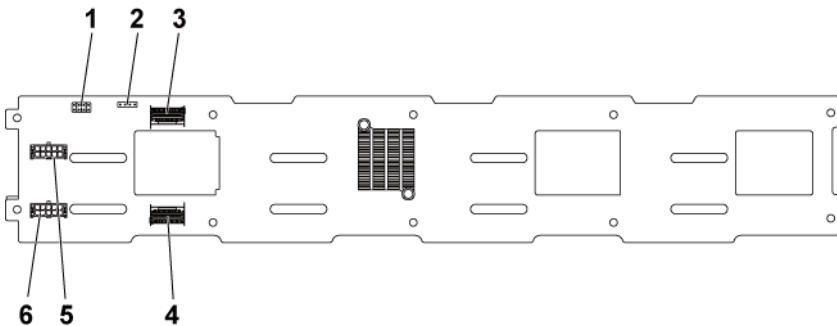

- | | | | |
|---|--|---|--|
| 1 | backplane jumper | 2 | UART connector |
| 3 | Mini-SAS ports 4-5 | 4 | Mini-SAS port 0-3 |
| 5 | backplane power connector for power supply 1 | 6 | backplane power connector for power supply 2 |

2.5" Hard-Drive Backplane With Expander

Figure 5-6. Front View of the Backplane

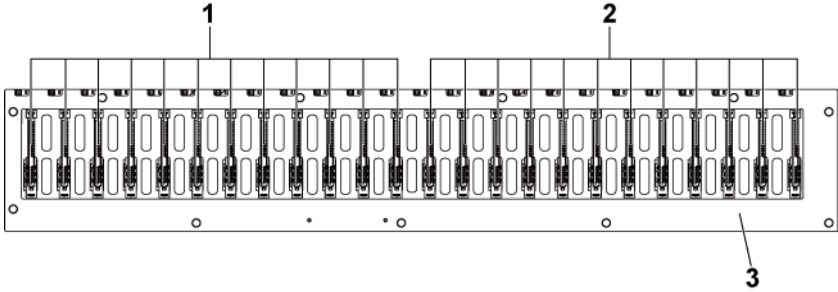

- | | | | |
|---|---|---|---|
| 1 | SATAII and SAS connectors 1-12
(from left to right) for system board 1 | 2 | SATAII and SAS connectors 1-12
(from left to right) for system board 2 |
| 3 | 2.5" backplane with expander | | |

Figure 5-7. Back View of the Backplane

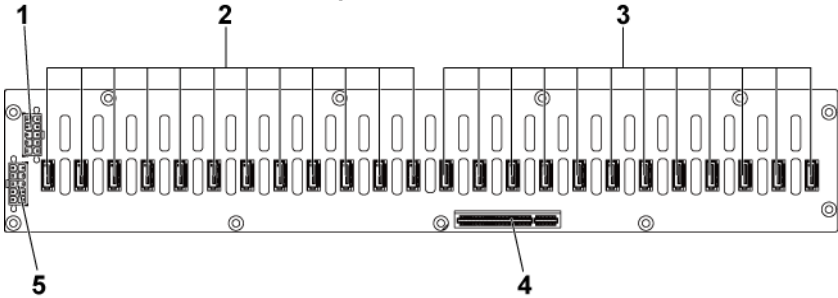

- | | | | |
|---|--|---|--|
| 1 | power-supply connector 1 | 2 | SATAII hard-drive connectors 1-12
(from right to left) for system board 2 |
| 3 | SATAII hard-drive connectors 1-12
(from right to left) for system board 1 | 4 | PCI-E x8 connector |
| 5 | power-supply connector 2 | | |

2.5" Hard-Drive Backplane Expander Card Connectors

Figure 5-8. 2.5" Hard-Drive Backplane Expander Card

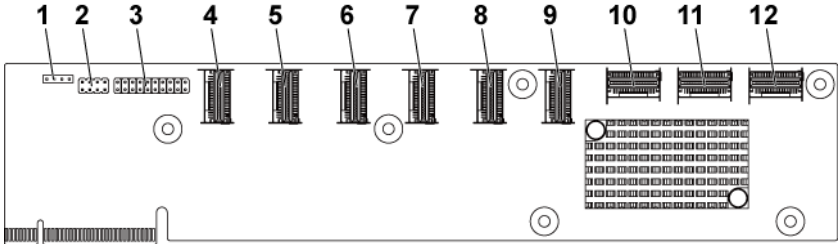

- | | | | |
|----|-----------------------------------|----|-----------------------------------|
| 1 | UART connector | 2 | expander card jumper |
| 3 | JTAG connector | 4 | mini-SAS connector 1 (port 1-4) |
| 5 | mini-SAS connector 2 (port 5-8) | 6 | mini-SAS connector 3 (port 9-12) |
| 7 | mini-SAS connector 4 (port 13-16) | 8 | mini-SAS connector 5 (port 17-20) |
| 9 | mini-SAS connector 6 (port 21-24) | 10 | system board 1 mini-SAS connector |
| 11 | system board 2 mini-SAS connector | 12 | system board 4 mini-SAS connector |

Middle Plane Connectors

Figure 5-9. Middle Plane Connectors

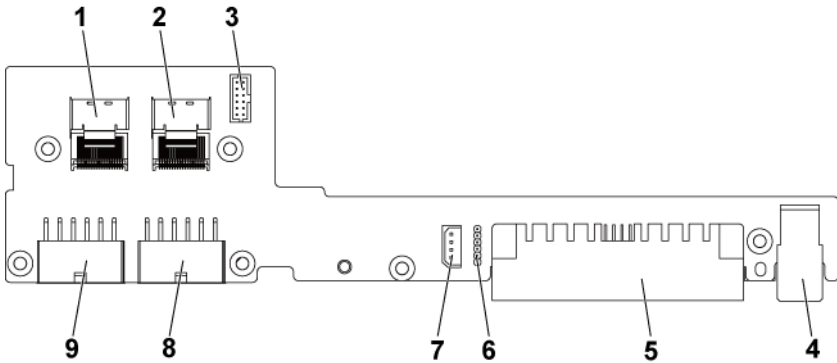

- | | | | |
|---|--|---|--|
| 1 | Mini-SAS connector for hard drive 1-4 | 2 | Mini-SAS connector for hard drive 5- 6 |
| 3 | fan controller board connector | 4 | signal connector |
| 5 | middle plane to system board power connector | 6 | CPLD JTAG to system board |
| 7 | IPMB connector | 8 | power connector 2 |
| 9 | power connector 1 | | |

Expansion Card Connectors

Figure 5-10. Expansion Card Connectors

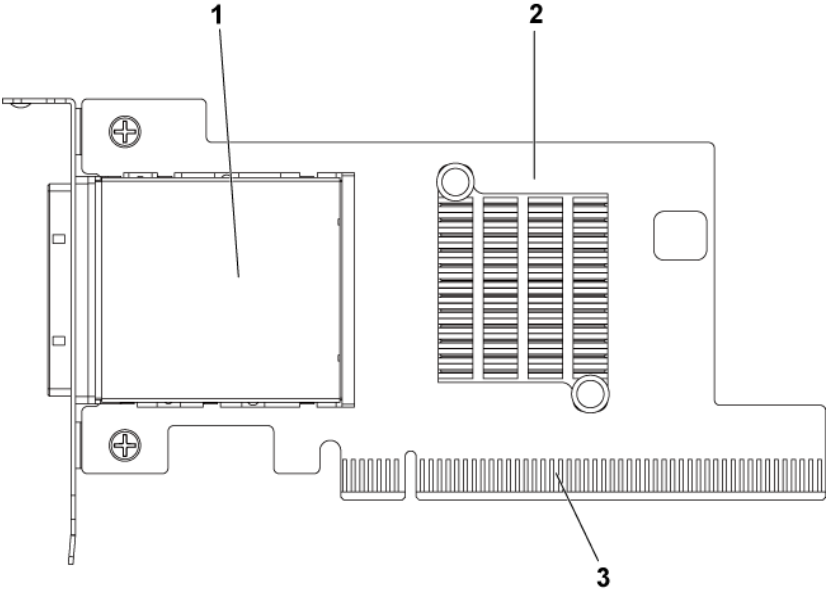

- 1 PCI-E Gen 2 x16 iPass connector
- 2 expansion card (HIC card)
- 3 PCI-E Gen 2 x16 golden fingers

SAS Mezzanine Card Connectors

Figure 5-11. SAS Mezzanine Card Connectors

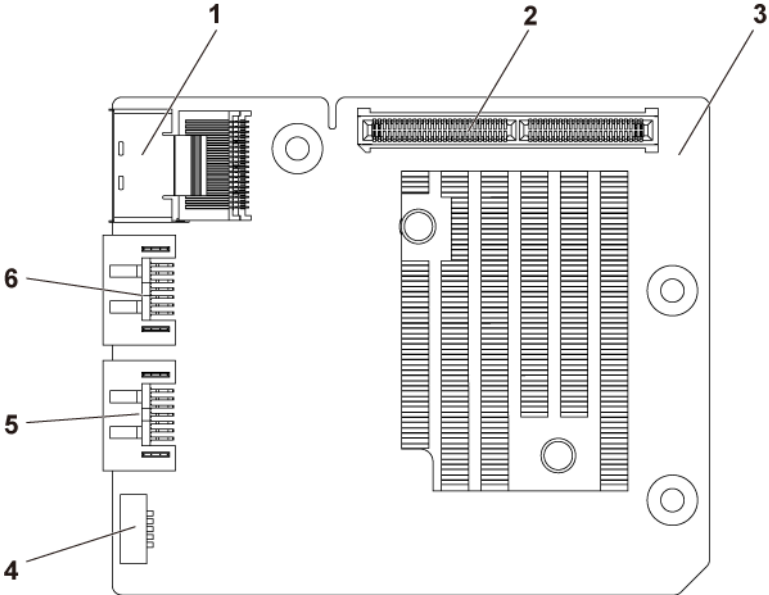

- | | | | |
|---|--------------------|---|-------------------------|
| 1 | Mini-SAS connector | 2 | PCI-E Gen2 x8 connector |
| 3 | SAS mezzanine card | 4 | SGPIO connector B |
| 5 | SAS port 5 | 6 | SAS port 4 |

10GbE Mezzanine Card Connectors

Figure 5-12. 10GbE Mezzanine Card Connectors

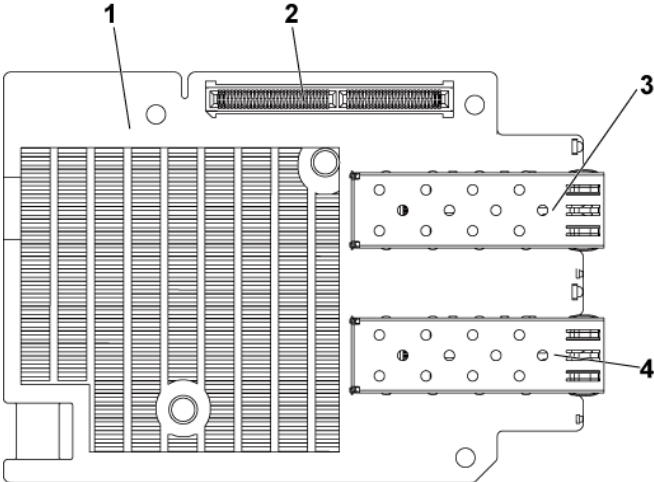

- | | | | |
|---|----------------------|---|-------------------------|
| 1 | 10GbE mezzanine card | 2 | PCI-E Gen2 x8 connector |
| 3 | SFP + port 1 | 4 | SFP + port 0 |

Fan Controller Board Connectors

Figure 5-13. Fan Controller Board Connectors

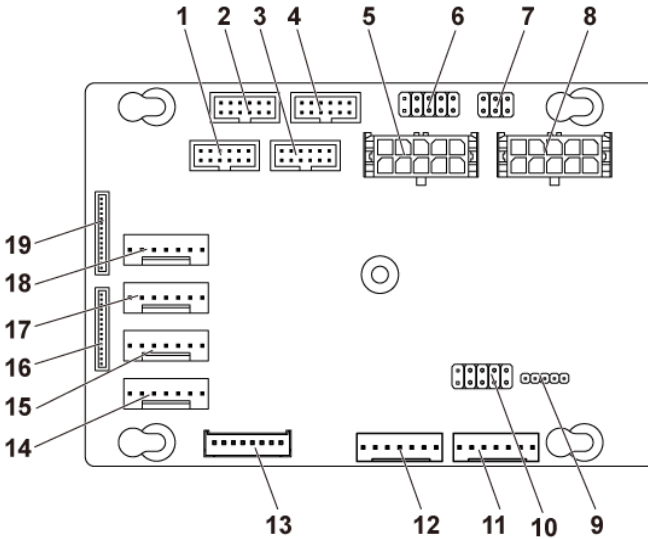

- | | | | |
|----|---|----|---|
| 1 | front-panel connector for system board 4 (not used) | 2 | front-panel connector for system board 2 |
| 3 | front-panel connector for system board 3 (not used) | 4 | front-panel connector for system board 1 |
| 5 | system fan board power connector 1 | 6 | *FCB firmware recovery and PS-ON connector |
| 7 | system fan speed control jumper | 8 | system fan board power connector 2 |
| 9 | FCB firmware update connector | 10 | product ID select and power throttling disable jumper |
| 11 | PMBus connector 2 | 12 | PMBus connector 1 |
| 13 | hard-drive backplane connector | 14 | system fan connector 4 |
| 15 | system fan connector 3 | 16 | front-panel connector 2 |
| 17 | system fan connector 2 | 18 | system fan connector 1 |
| 19 | front-panel connector 1 | | |



NOTE: Pin 9 and pin 10 of FCB firmware recovery and PS-ON connector are used for firmware recovery, and pin 1-8 are used for debug when pin 9 and pin 10 are shorted by jumper.

Power Distribution Board Connectors

Figure 5-14. Power Distribution Board Connectors

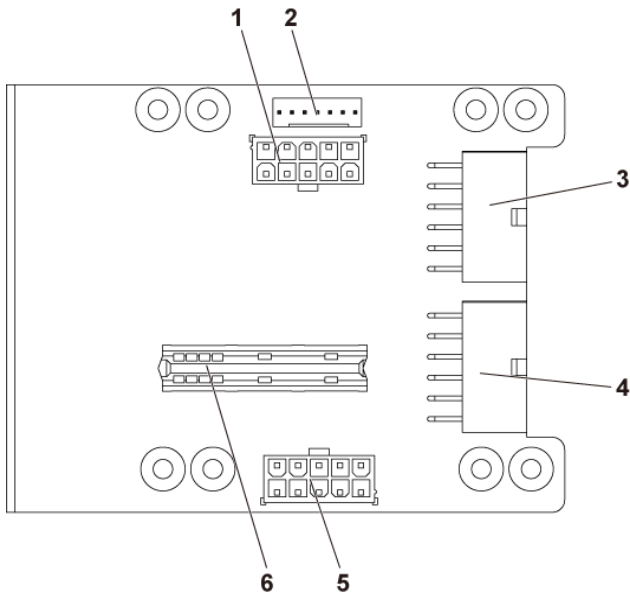

- | | | | |
|---|--------------------------------------|---|------------------------|
| 1 | hard-drive backplane power connector | 2 | PMbus connector |
| 3 | main power connector 1 | 4 | main power connector 2 |
| 5 | system fan board power connector | 6 | bridge card connector |

Sensor Board Connectors

Figure 5-15. Sensor Board Connectors

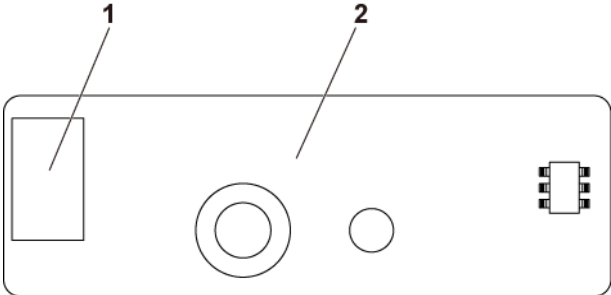

1 power connector

2 sensor board

Switch and Jumper Settings



CAUTION: Many repairs may only be done by a certified service technician. You should only perform troubleshooting and simple repairs as authorized in your product documentation, or as directed by the online or telephone service and support team. Damage due to servicing that is not authorized by Dell is not covered by your warranty. Read and follow the safety instructions that came with the product.

System Configuration Switch Settings

The function of system configuration switch installed on each system board is shown below:

Figure 5-16. System Configuration Switch

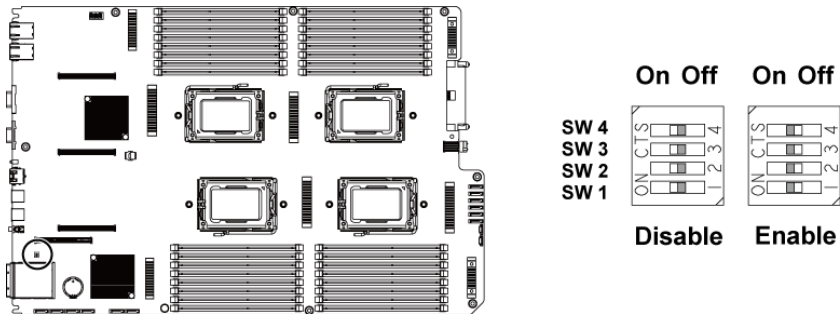

Table 5-1. System Configuration Switch

Jumper	Function	Off	On
SW 1	NVRAM Clear	*Disable	Enable
SW 2	System Reset	*Disable	Enable
SW 3	Clear Password Enable	*Disable	Enable
SW 4	BMC NMI Enable	*Disable	Enable



NOTE: The * in the table of system configuration jumper describes the default status and the default state is not active state.

3.5" Backplane With CPLD Jumper Settings



CAUTION: Many repairs may only be done by a certified service technician. You should only perform troubleshooting and simple repairs as authorized in your product documentation, or as directed by the online or telephone service and support team. Damage due to servicing that is not authorized by Dell is not covered by your warranty. Read and follow the safety instructions that came with the product.

Figure 5-17. Jumpers Installed on 3.5" Backplane With CPLD

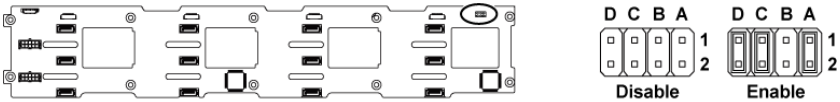

Table 5-2. Jumpers Installed on 3.5" Backplane With CPLD

Jumper	Function	Off	On
A	LED Control	*Disable	Enable
B	Reserved	—	—
C	Protocol Select	*I ² C Protocol Selected	SGPIO Protocol Selected
D	MLB Mode Select	*Normal Operation	LED Test



NOTE: The * in the table of backplane jumper describes the default status and the default state is not active state.

3.5" Backplane With Expander Jumper Settings



CAUTION: Many repairs may only be done by a certified service technician. You should only perform troubleshooting and simple repairs as authorized in your product documentation, or as directed by the online or telephone service and support team. Damage due to servicing that is not authorized by Dell is not covered by your warranty. Read and follow the safety instructions that came with the product.

Figure 5-18. Jumpers Installed on 3.5" Backplane With Expander

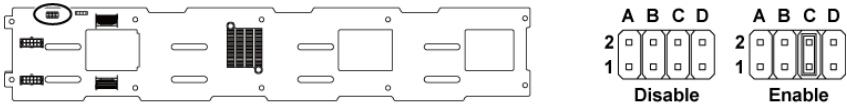

Table 5-3. Jumpers Installed on 3.5" Backplane With Expander

Jumper	Function	Off	On
A	Project_select <1>	Reserved for factory setting	Reserved for factory setting
B	Project_select <0>	Reserved for factory setting	Reserved for factory setting
C	BOB_UART_SEL	*General UART Port Selected	Serial Debug Port Selected
D	NC_J14_PIN7		No function



NOTE: The * in the table of backplane jumper describes the default status and the default state is not active state.

2.5" Backplane Expander Card Jumper Settings



CAUTION: Many repairs may only be done by a certified service technician. You should only perform troubleshooting and simple repairs as authorized in your product documentation, or as directed by the online or telephone service and support team. Damage due to servicing that is not authorized by Dell is not covered by your warranty. Read and follow the safety instructions that came with the product.

The function of jumper installed on the expander card for 2.5" backplane is shown below:

Figure 5-19. Jumpers Installed on 2.5" Backplane Expander Card

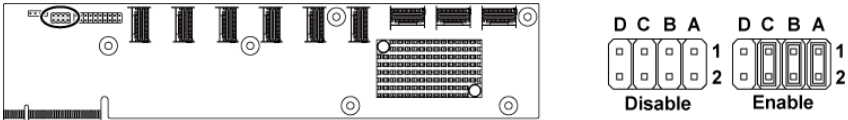

Table 5-4. Jumpers Installed on 2.5" Backplane Expander Card

Jumper	Function	Off	On
A	SAS Card Selection	*Disable	Enable
B	MLB Mode Selection	*Disable	Enable
C	UART Selection	*Disable	Enable
D	Reserved	—	—



NOTE: The * in the table of system configuration jumper describes the default status and the default state is not active state.

Getting Help

Contacting Dell

For customers in the United States, call 800-WWW-DELL (800-999-3355).



NOTE: If you do not have an active Internet connection, you can find contact information on your purchase invoice, packing slip, bill, or Dell product catalog.

Dell provides several online and telephone-based support and service options. Availability varies by country and product, and some services may not be available in your area. To contact Dell for sales, technical support, or customer service issues:

- 1 Visit **support.dell.com**. Click your country/region at the bottom of the page. For a full listing of country/region, click **All**. Click **All Support** from **Support** menu.
- 2 Select the appropriate service or support link based on your need.
- 3 Choose the method of contacting Dell that is convenient for you.

Index

A

about your system, 11

B

back panel features, 17

backplane

installing, 187

removing, 184

backplane jumper settings, 243, 244

batteries

troubleshooting, 217

battery (system)

replacing, 169

blank

hard drive, 105

C

Cable Routing for Fan Control Board,
194

Cable Routing for Power Distribution
Board, 191

collecting system event log, 25

contacting dell, 246

cooling fans

installing, 176

removing, 175

troubleshooting, 220

D

damaged systems

troubleshooting, 217

daughter card

installing, 153, 157, 160

removing, 151, 155, 158

Dell

contacting, 246

drive blank

installing, 106

removing, 105

E

expansion card

installing, 127, 132, 142

removing, 125, 129, 139

troubleshooting, 225

expansion card connector

installing, 150

removing, 149

F

fan controller board removing, 192

features and indicators

front panel, 12

front panel features, 12

front panel installing, 203

front panel removing, 200

H

hard drive

- installing hot-swap hard drive, 107
- removing, 106
- removing a hot-swap hard drive, 106

troubleshooting, 222

heat sink installing, 119

heat sink removing, 118

heat sinks

- installing, 119
- removing, 118

I

indicator codes

- AC power, 23
- hard-drive indicator, 15

NIC, 20

NIC (Management Port), 21

power and system board, 22

indicators

- back panel, 17
- front panel, 12

installing

- backplanes, 187
- cooling fans, 176
- expander card, 199
- expansion card, 127, 132, 142
- expansion card connector, 150
- front panel, 203
- hard drive blank, 106
- heat sink, 119
- hot-swap hard drive, 107
- memory modules, 167
- middle planes, 182
- power supply, 114
- processor, 124

SAS daughter card, 153, 157, 160

sensor board, 206

system board, 172

system board assembly, 116

Installing the Mezzanine-Card Bridge Board, 162

K

keyboards

troubleshooting, 213

L

LEDs

BMC heart beat, 24

M

memory

troubleshooting, 220

memory modules

- installing, 167
- removing, 166

memory modules (DIMMs)

configuring, 163

middle planes

- installing, 182
- removing, 177

N

NICs

troubleshooting, 215

P

phone numbers, 246

POST
 accessing system features, 11
power distribution board
 removing, 188
power supplies
 installing, 114
 removing, 113
processor
 installing, 124
 removing, 122
processors
 troubleshooting, 226

R

removing
 backplanes, 184
 cooling fans, 175
 daughter card, 151, 155, 158
 expander card, 195
 expansion card, 125, 129, 139
 expansion card connector, 149
 fan controller board, 192
 front panel, 200
 hard drive, 106
 hard drive blank, 105
 heat sink, 118
 hot-swap hard drive, 106
 memory modules (DIMMs), 166
 middle planes, 177
 power distribution board, 188
 power supply, 113
 processor, 122
 sensor board, 204
 system board, 171
 system board assembly, 115
Removing the Mellanox Card, 158
Removing the Mezzanine-Card Bridge

Board, 161
replacing
 system battery, 169

S

safety, 103
SAS controller daughter card
 troubleshooting, 223
SAS RAID controller daughter card
 troubleshooting, 223
startup
 accessing system features, 11
support
 contacting Dell, 246
system
 closing, 174
 opening, 174
system board
 connectors, 229
 installing, 172
 jumper settings, 242
 removing, 171
system board assembly
 installing, 116
 removing, 115
system cooling
 troubleshooting, 219
system features
 accessing, 11
system setup
 boot settings configuration, 72
 memory configuration, 56, 57, 58, 59
 PCI configuration, 65, 67, 68
 processor configuration, 53
 processor settings, 51
 remote access configuration, 85

- SATA configuration, 60, 63
- system memory, 51
- USB configuration, 64

T

- telephone number, 246
- troubleshooting
 - cooling fans, 220
 - damaged system, 217
 - expansion card, 225
 - external connections, 213
 - hard drive, 222
 - keyboard, 213
 - memory, 220
 - NIC, 215
 - processors, 226
 - SAS RAID controller daughter card, 223

- sequence, 212
- system battery, 217
- system boot issues, 25
- system cooling, 219
- video, 213
- wet system, 216

V

- video
 - troubleshooting, 213

W

- warranty, 44
- wet system
 - troubleshooting, 216